

Ursula

Jurk / Robe /
Dress / Kleid

Maten / Tailles / Sizes / Größen:

.....	30
-----	32
-----	34
- . - . - . - . - . - . - . - . - .	36
-----	38
- . - . - . - . - . - . - . - . - .	40
-----	42
.....	44
.....	46
.....	48

Patroondelen / Pièces du patron /
Pattern pieces / Schnittteile:

- A** voorpand / devant / front panel /
Vorderteil
- B** rugpand / dos / back panel /
Rückenteil
- C** rokboord / volant jupe / skirt panel /
Rockbund
- D** polopat VP / patte de fermeture DV /
polo placket FP / Pololeiste VT
- E** kraag / col / collar / Kragen
- F** mouw / manche / sleeve / Ärmel
- G** polsboord / bord manchette / cuff /
Manschette

Patroonschema / Schéma du Patron / Pattern Diagram /
Übersichtsplan zum Zusammenkleben

1	2	3	4	5	6
7	8	9	10	11	12
13	14	15	16	17	18
19	20	21	22	23	24
25	26	27	28	29	30
31	32	33			

Controlevierkant / Carré de controle
/ Test square / Kontrollquadrat

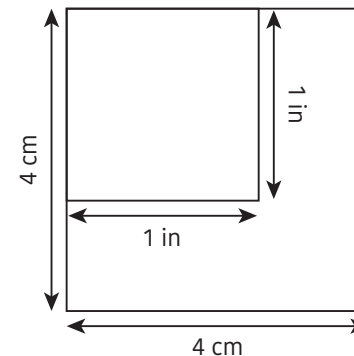

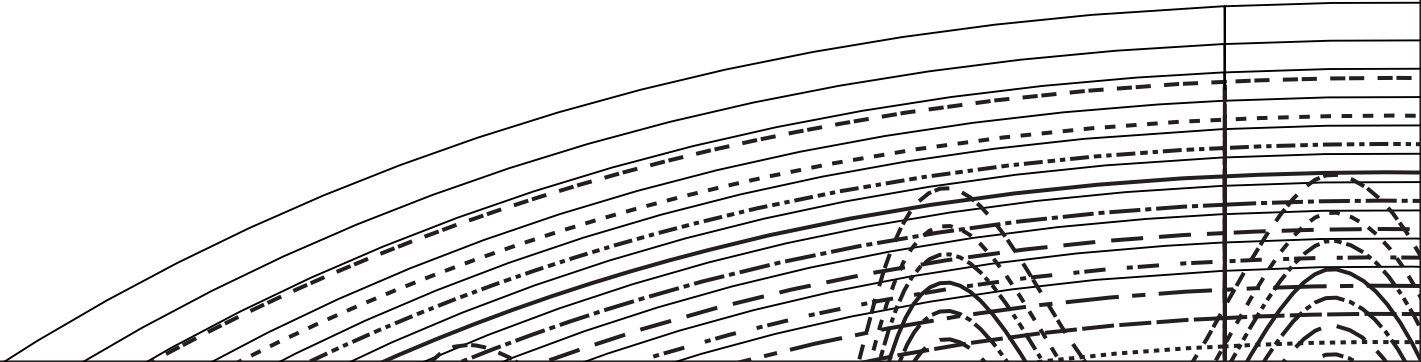

3

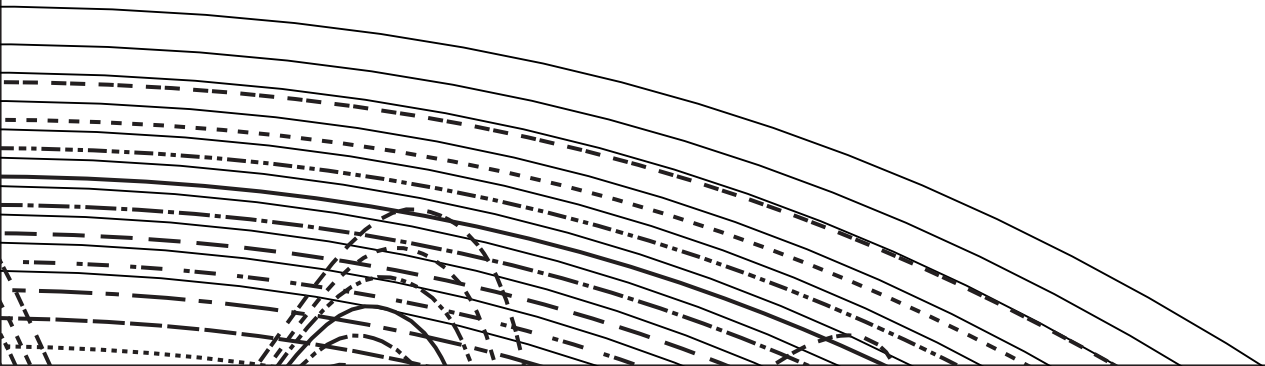
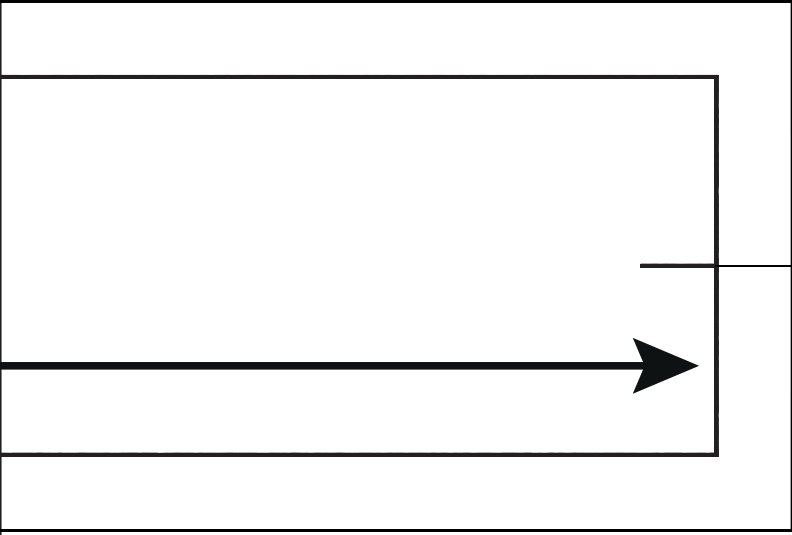

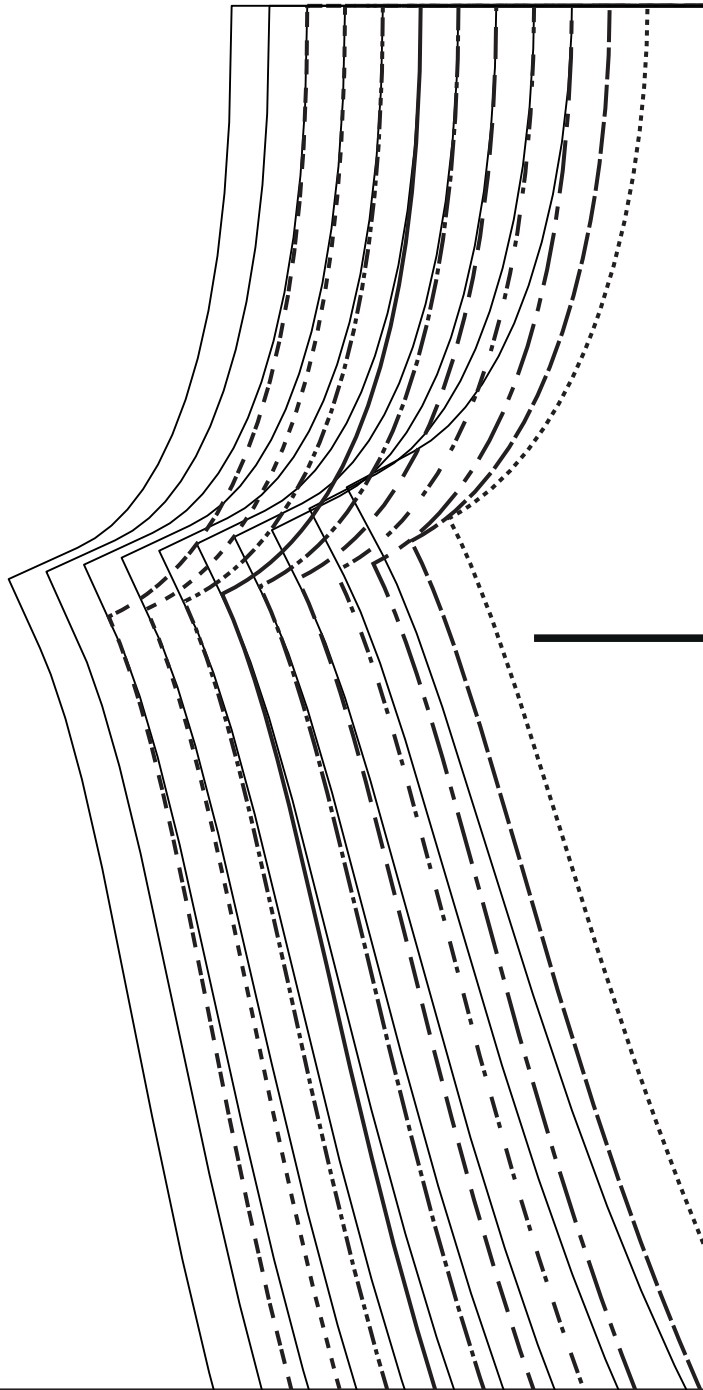



B



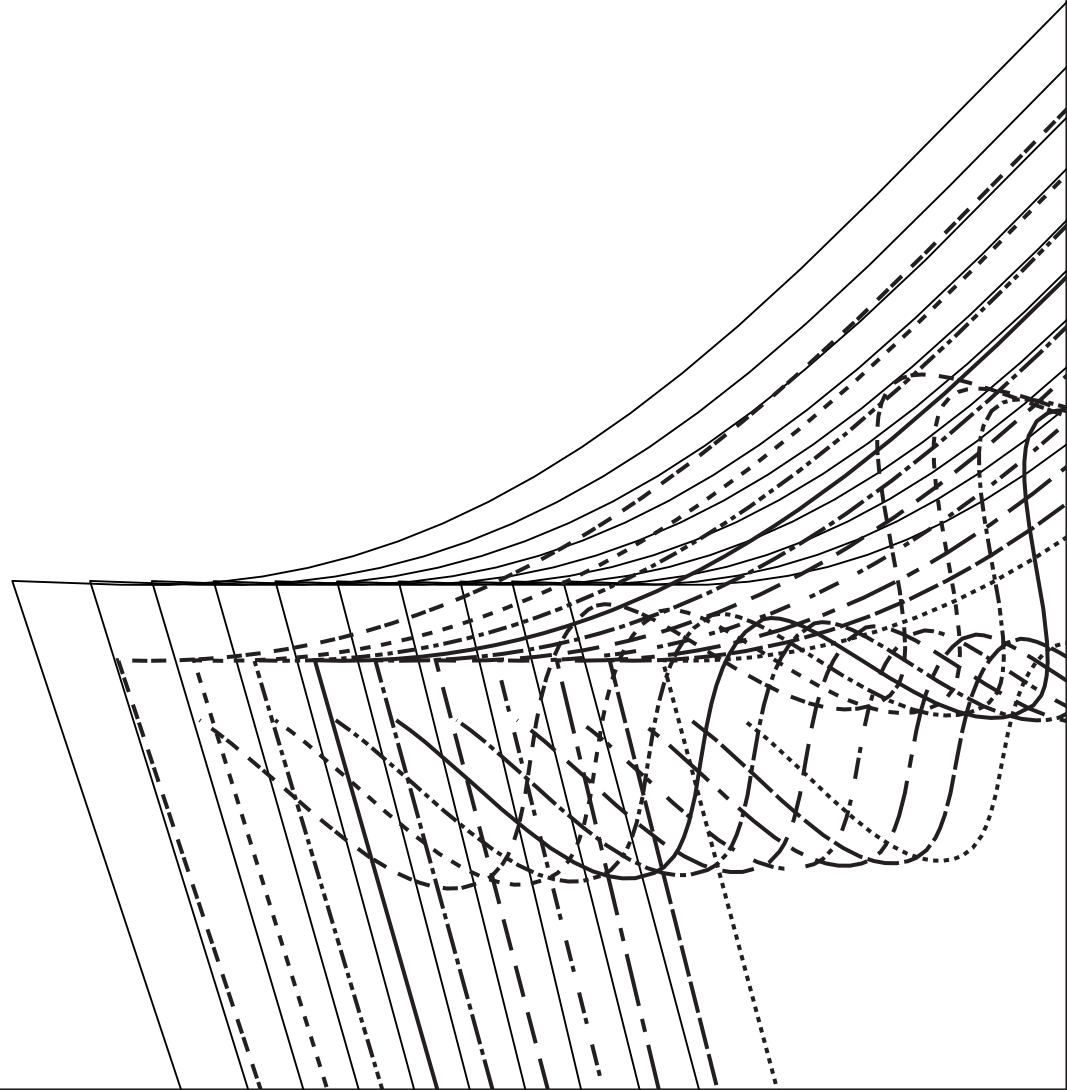

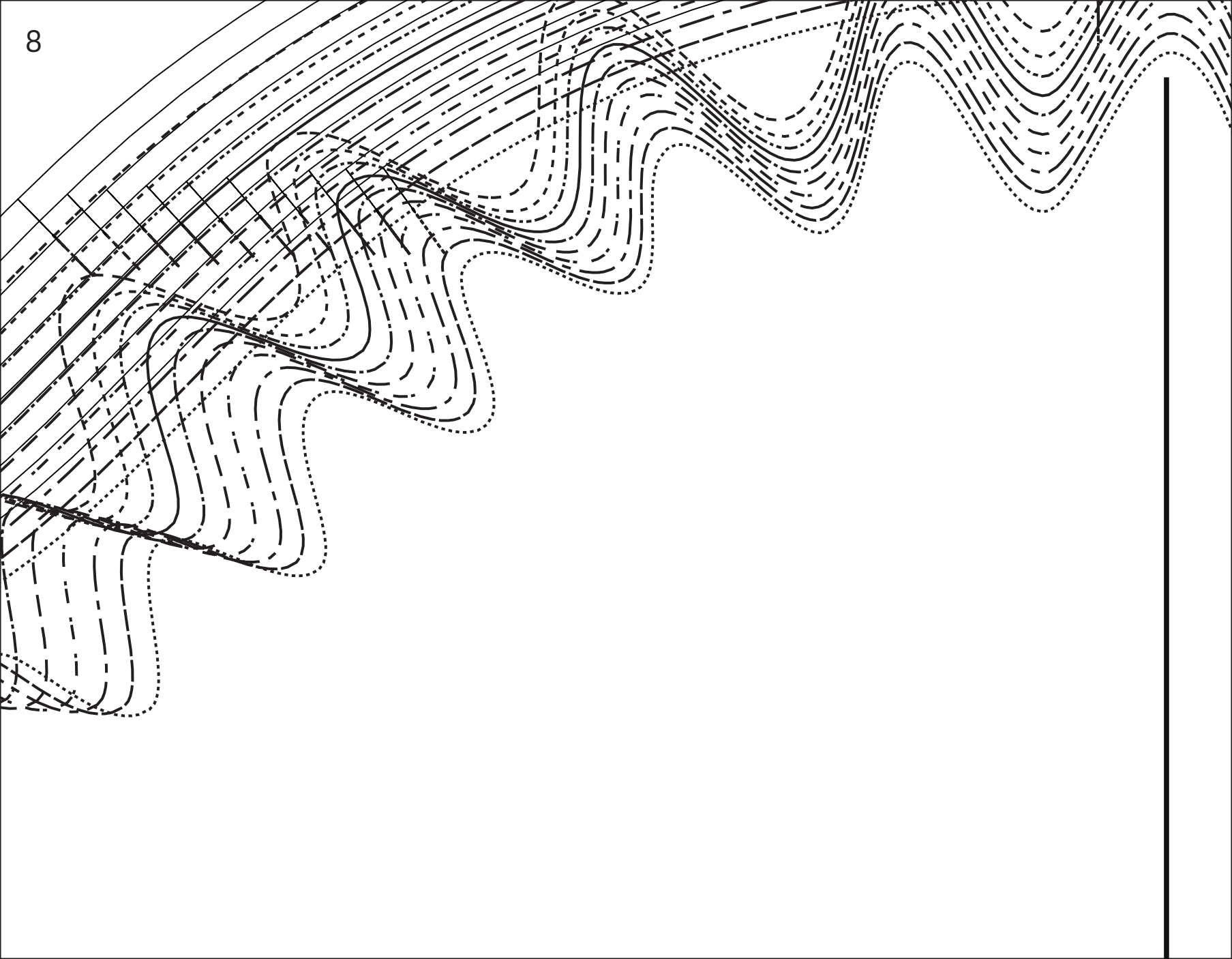

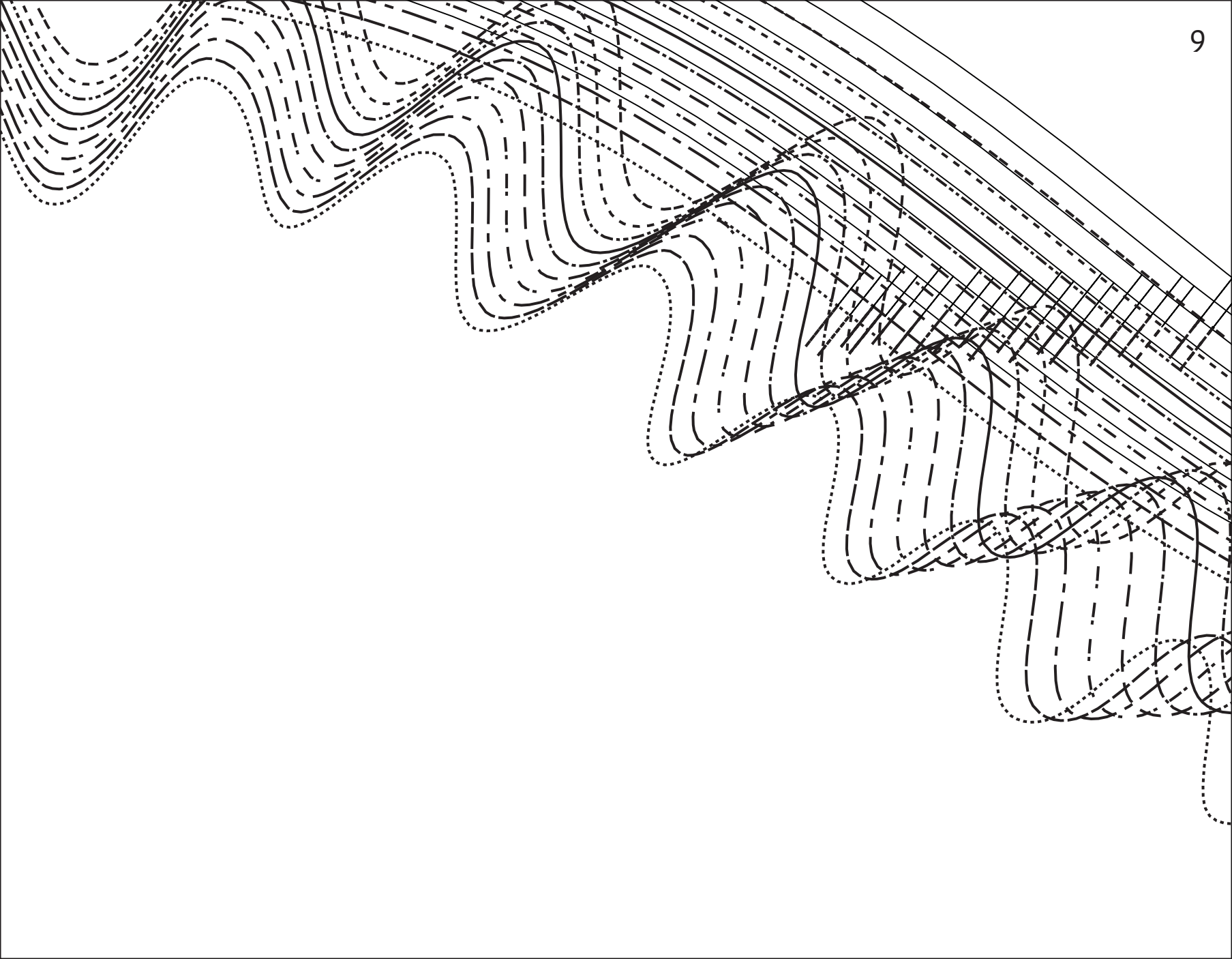

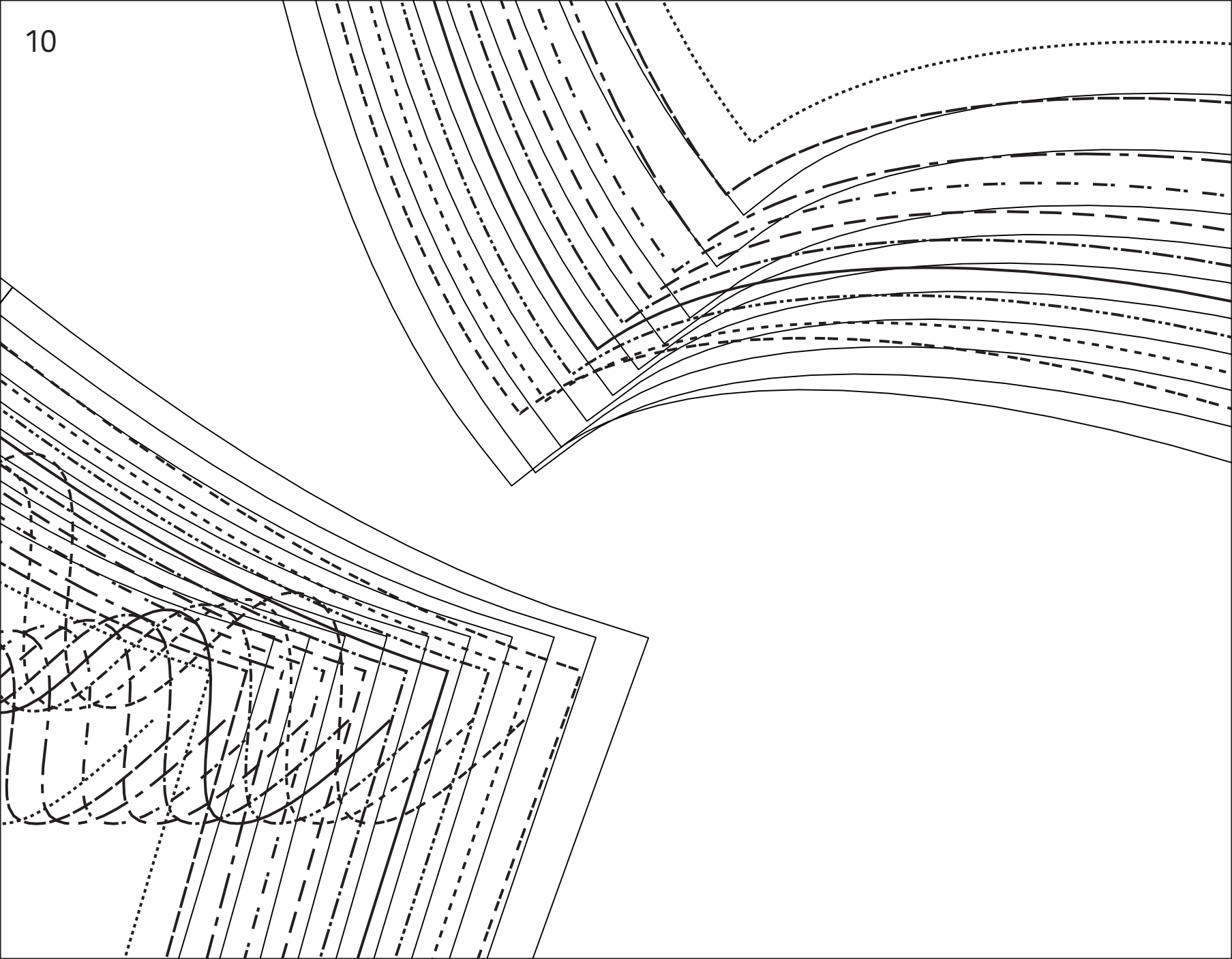

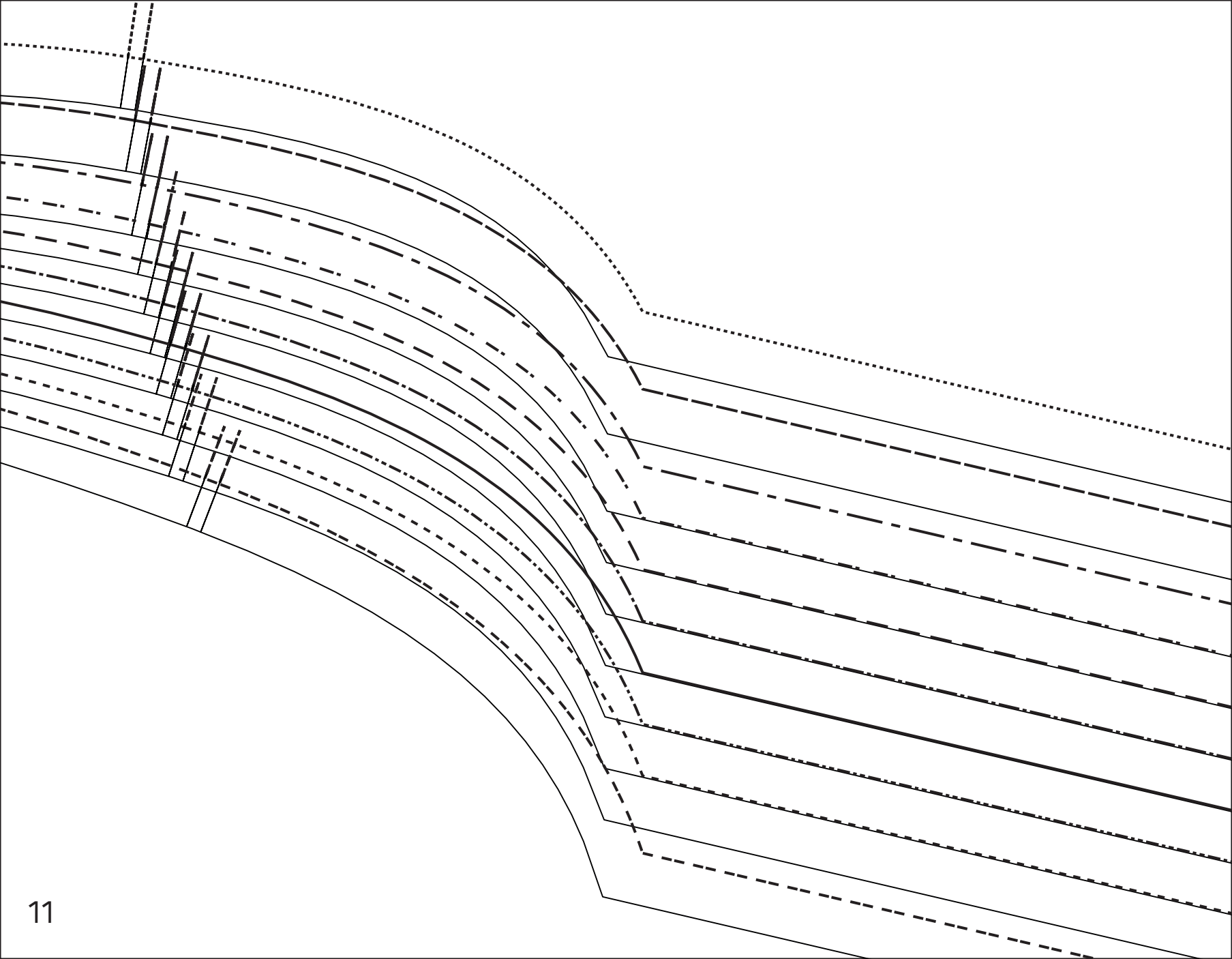

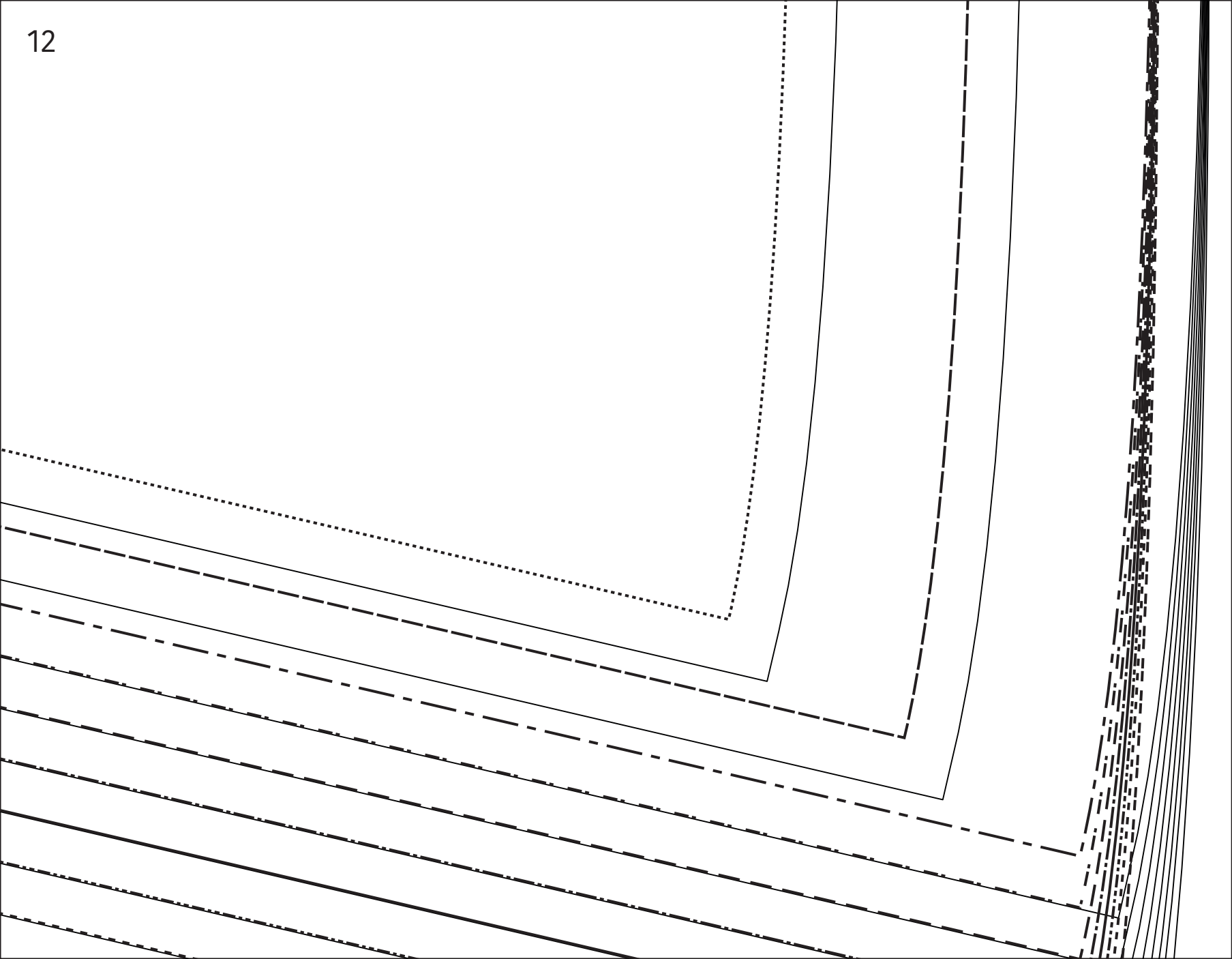

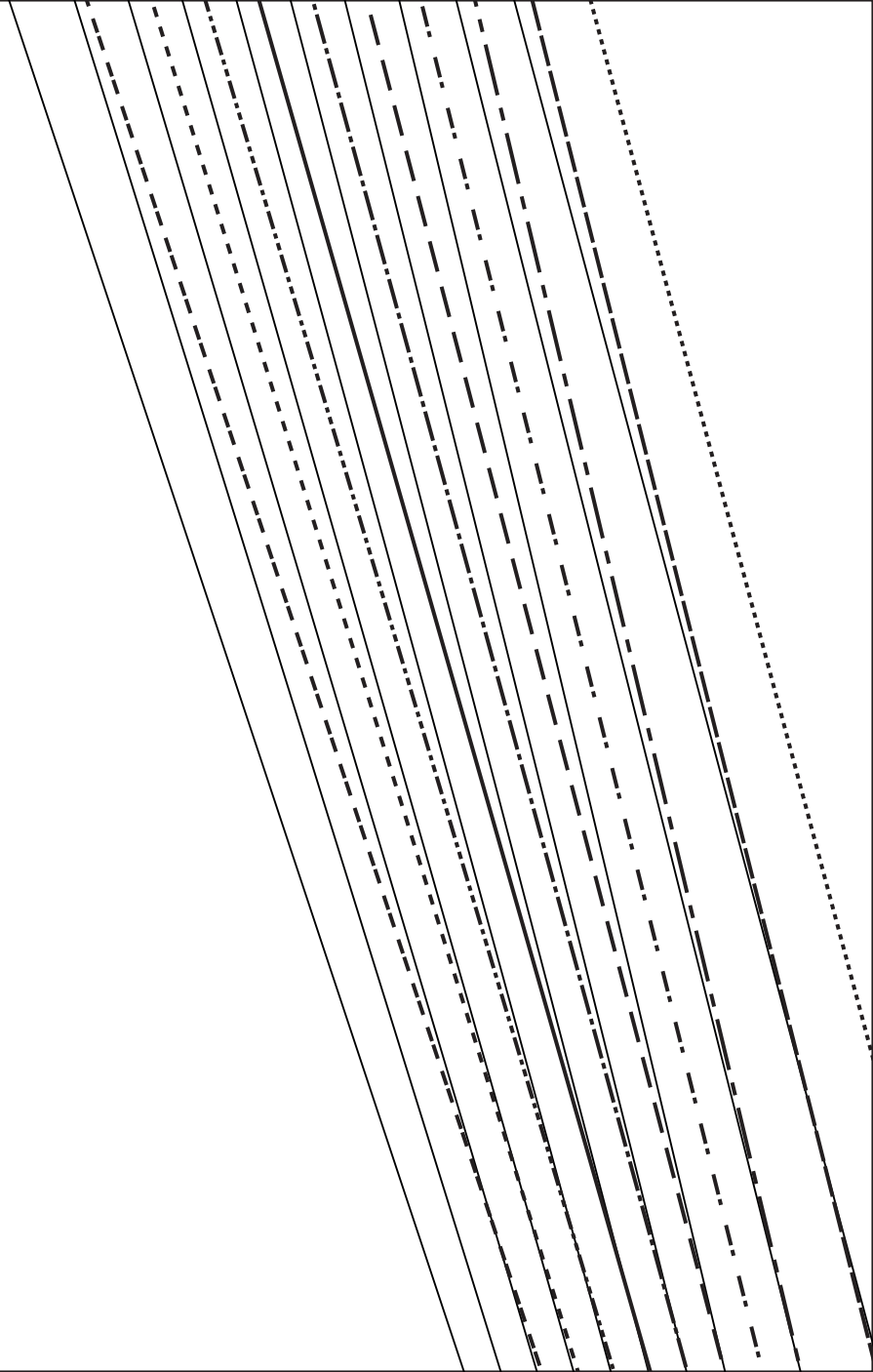
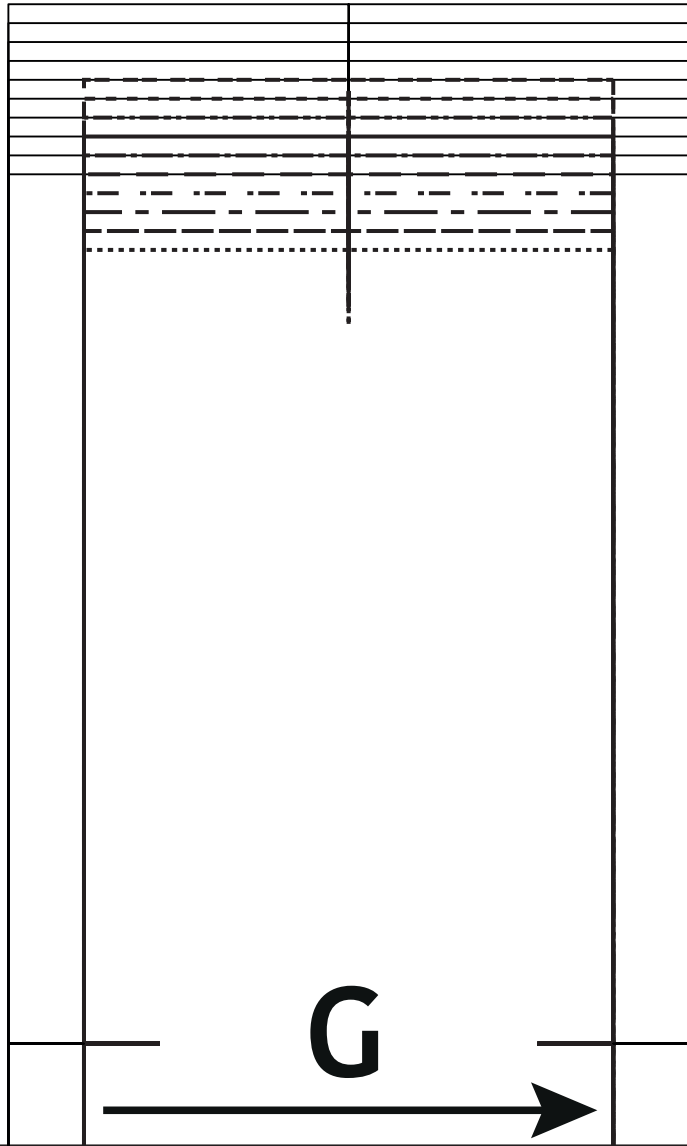

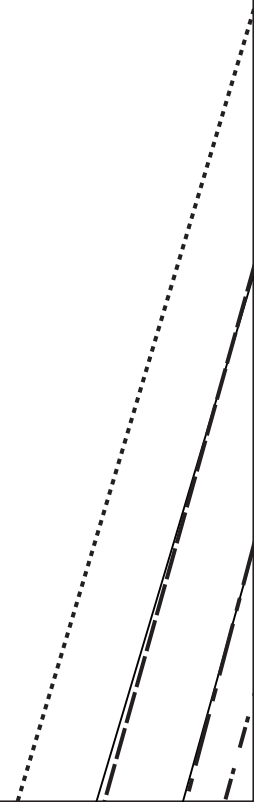

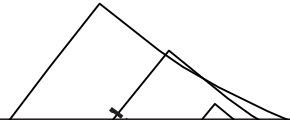
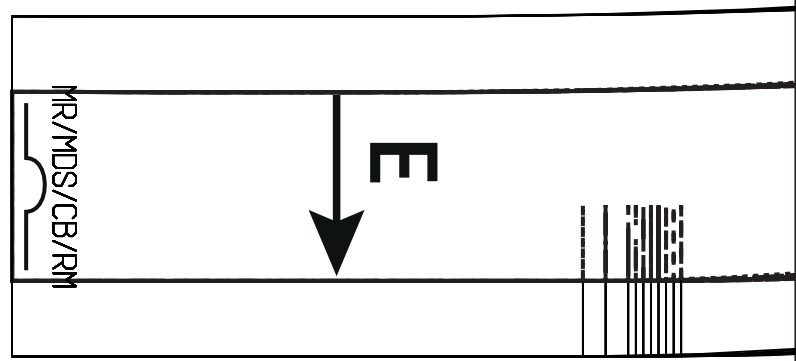
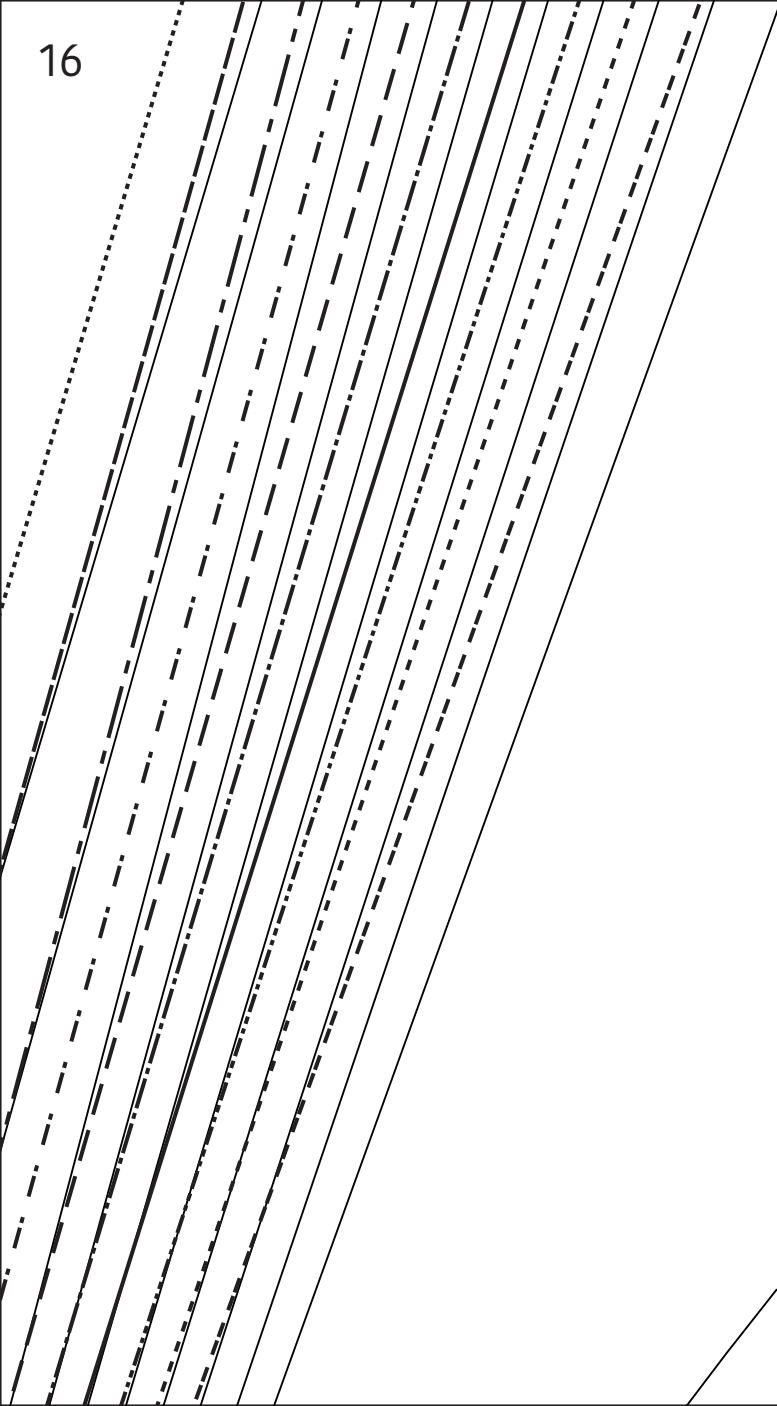

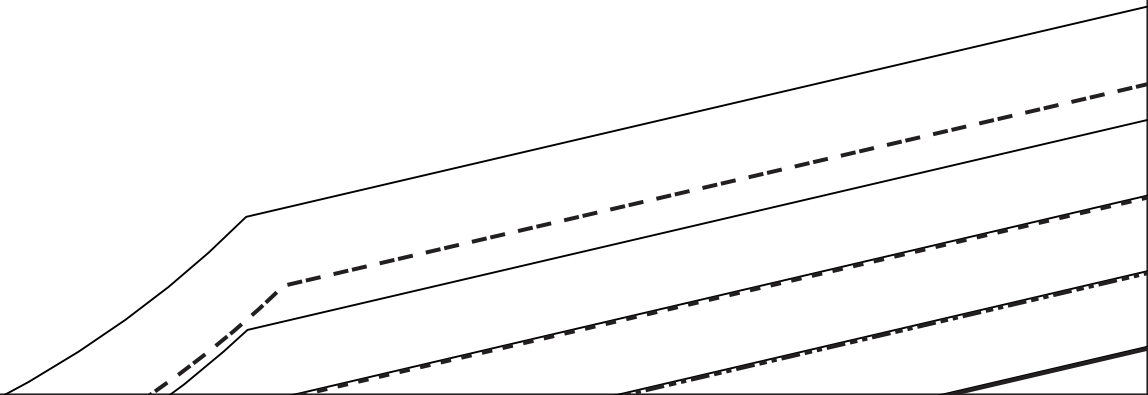
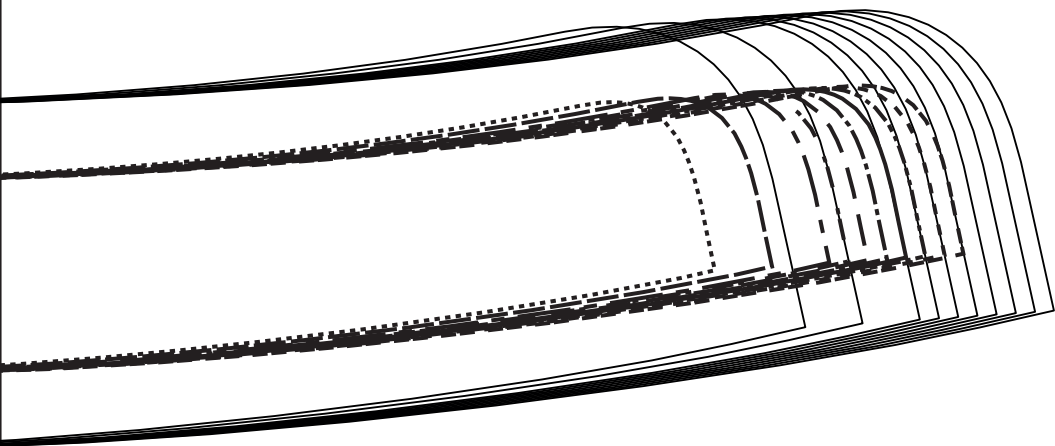

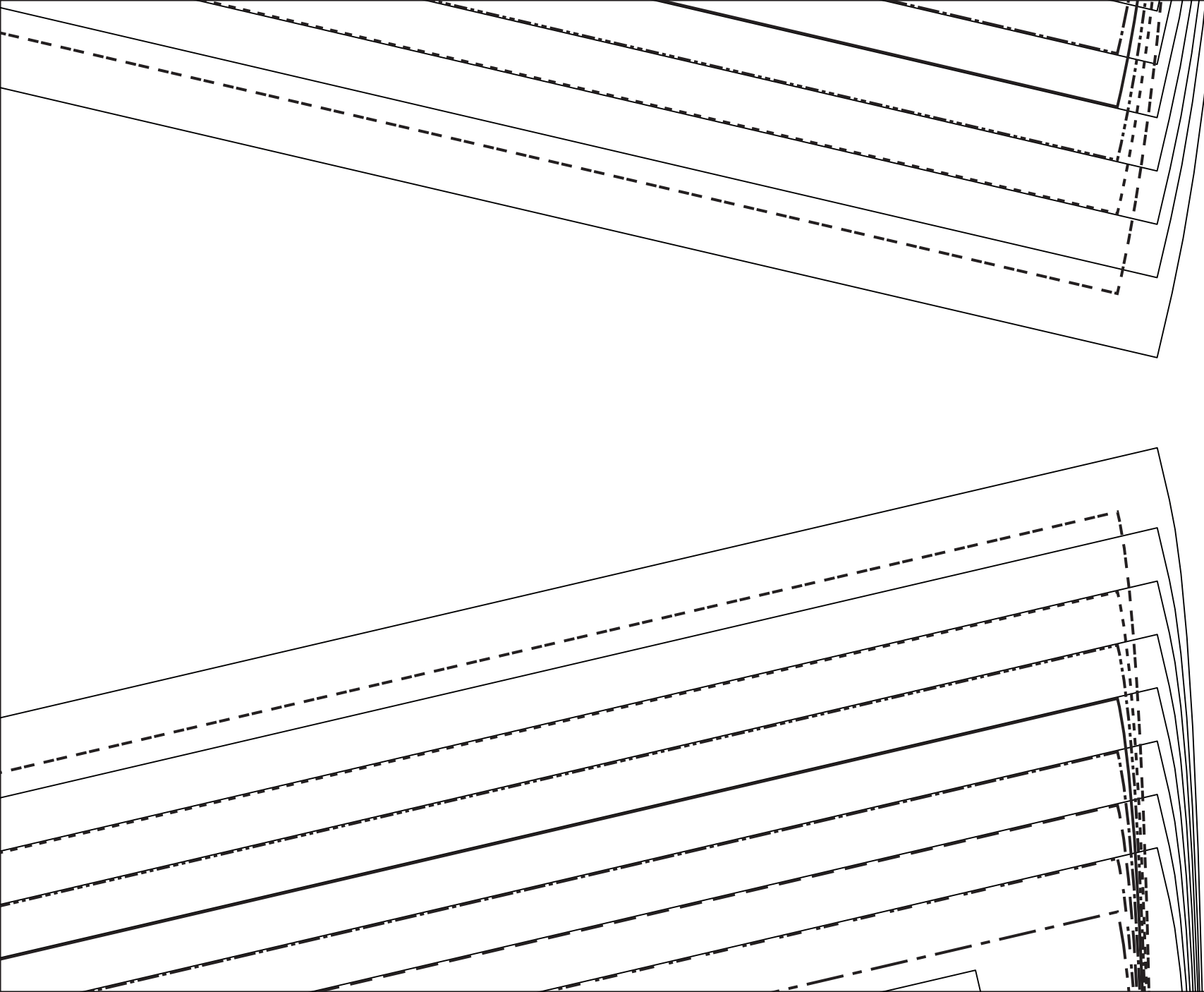

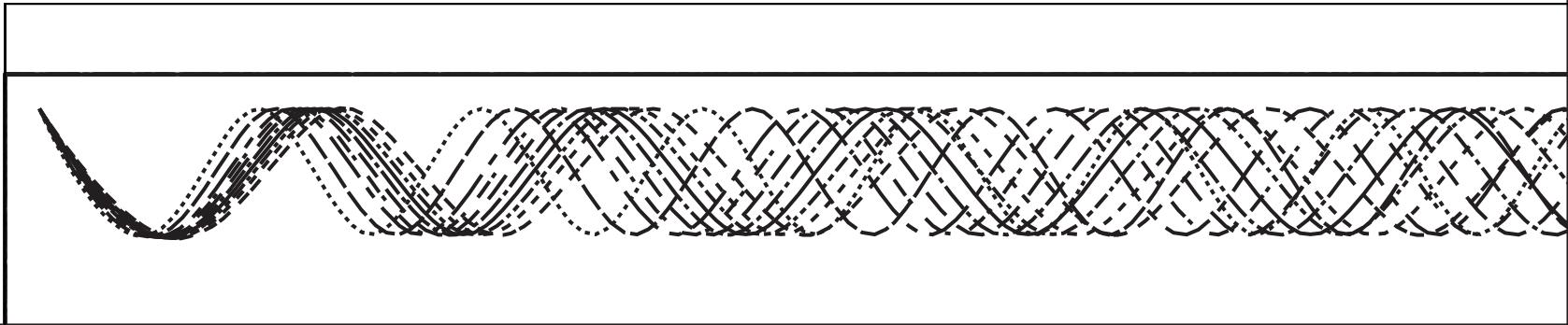
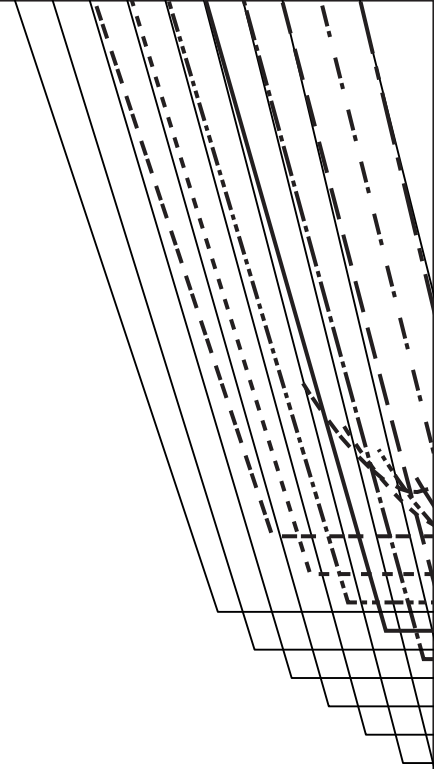
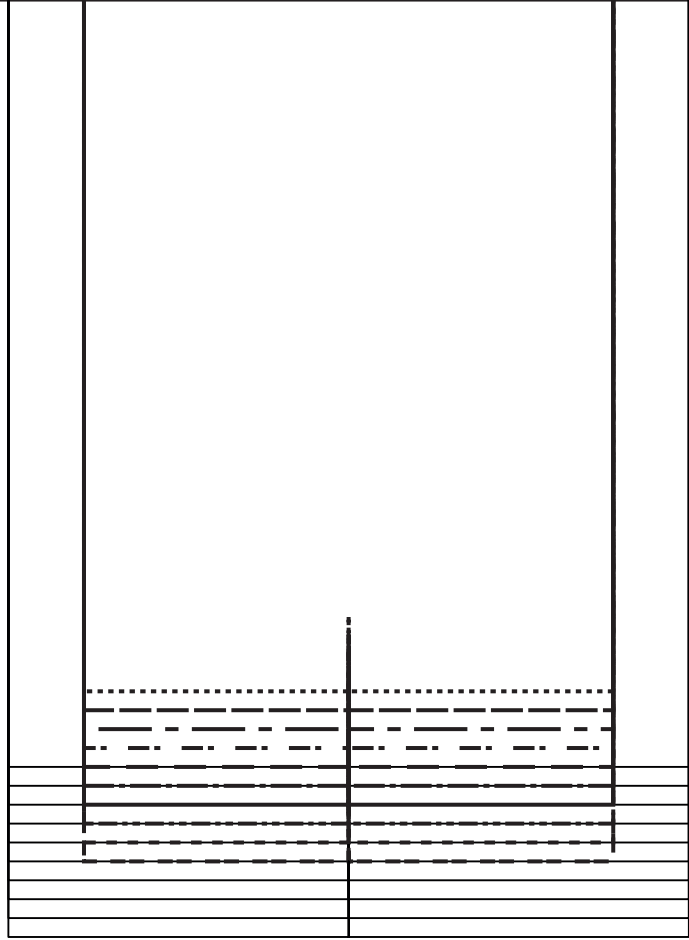

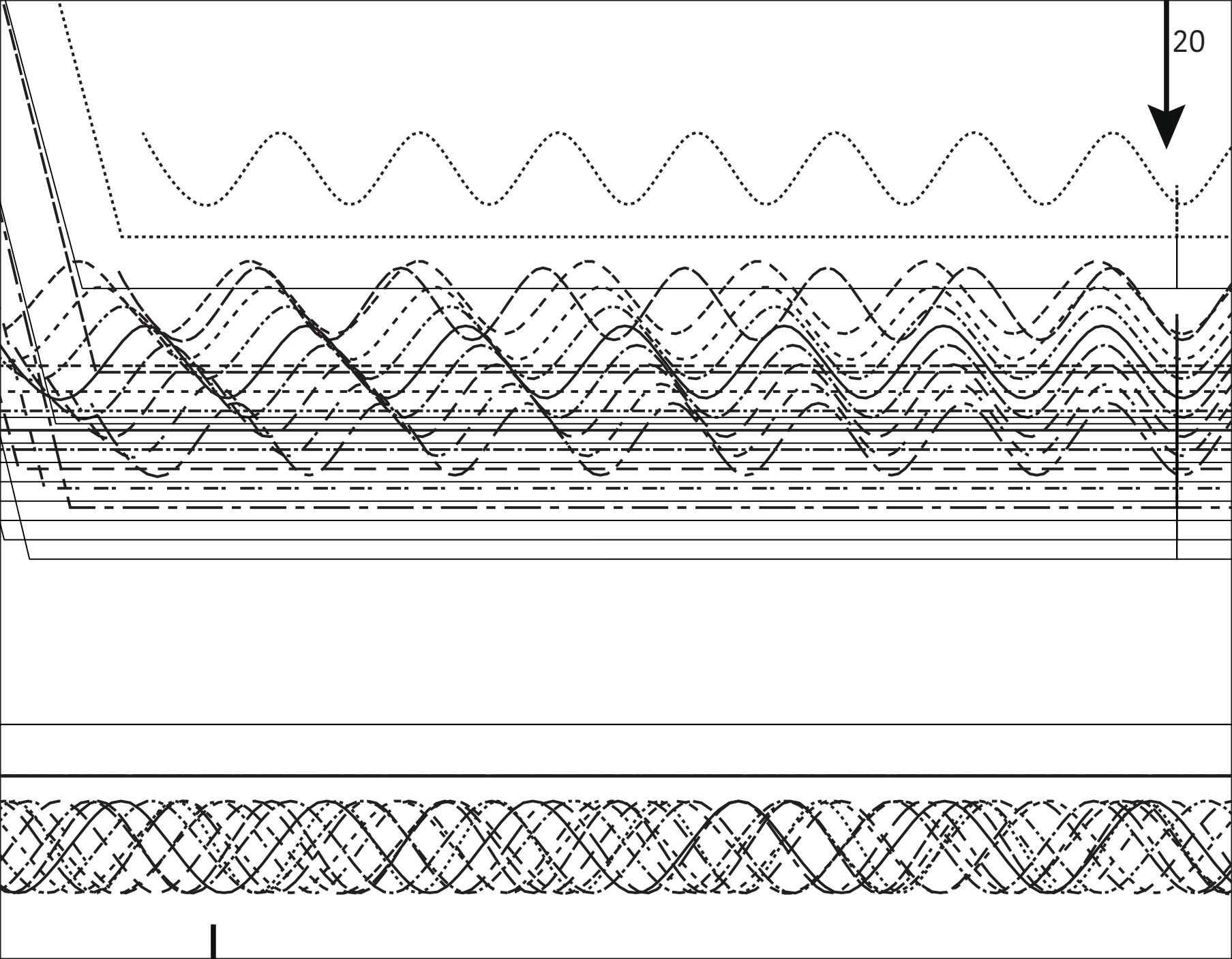

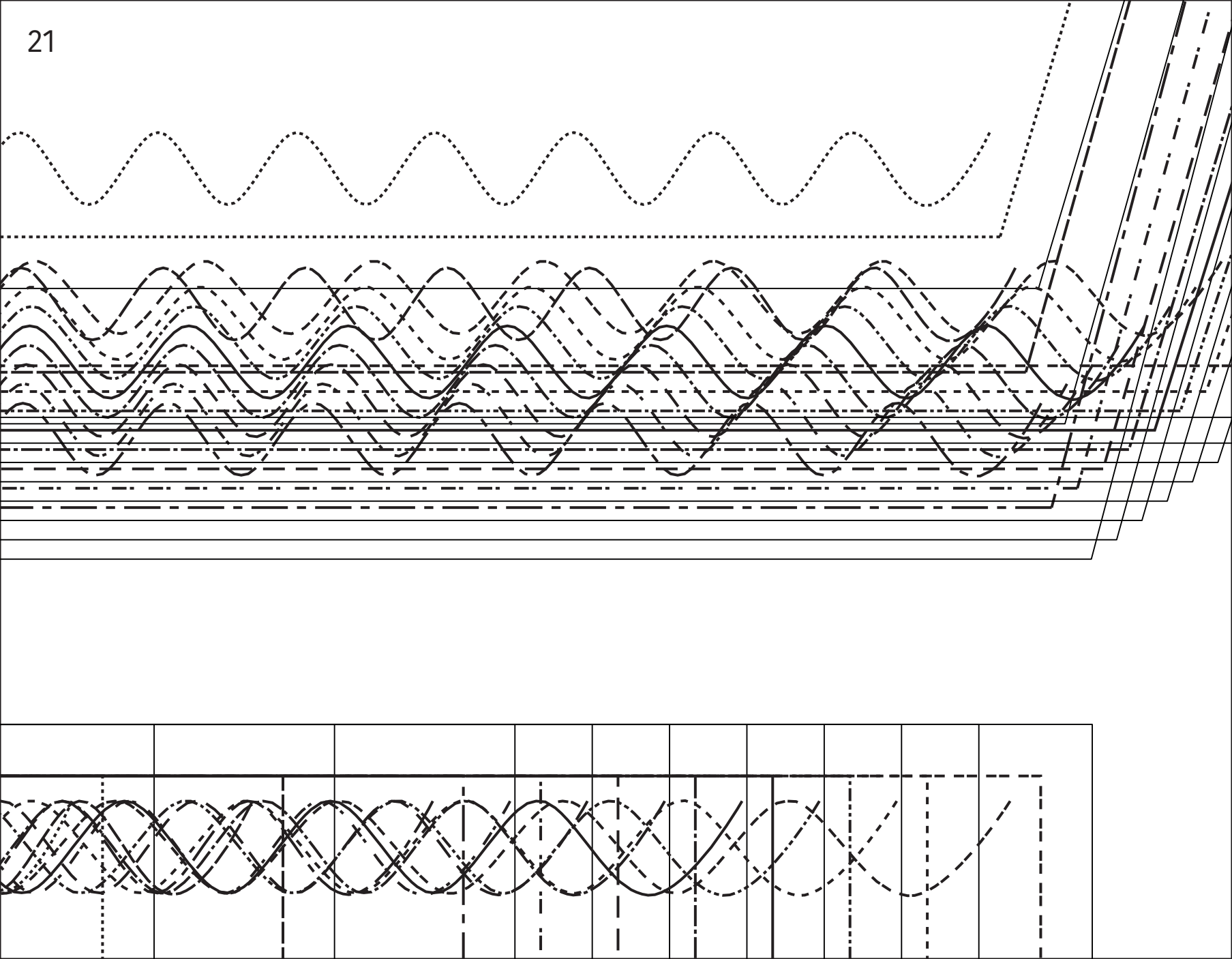

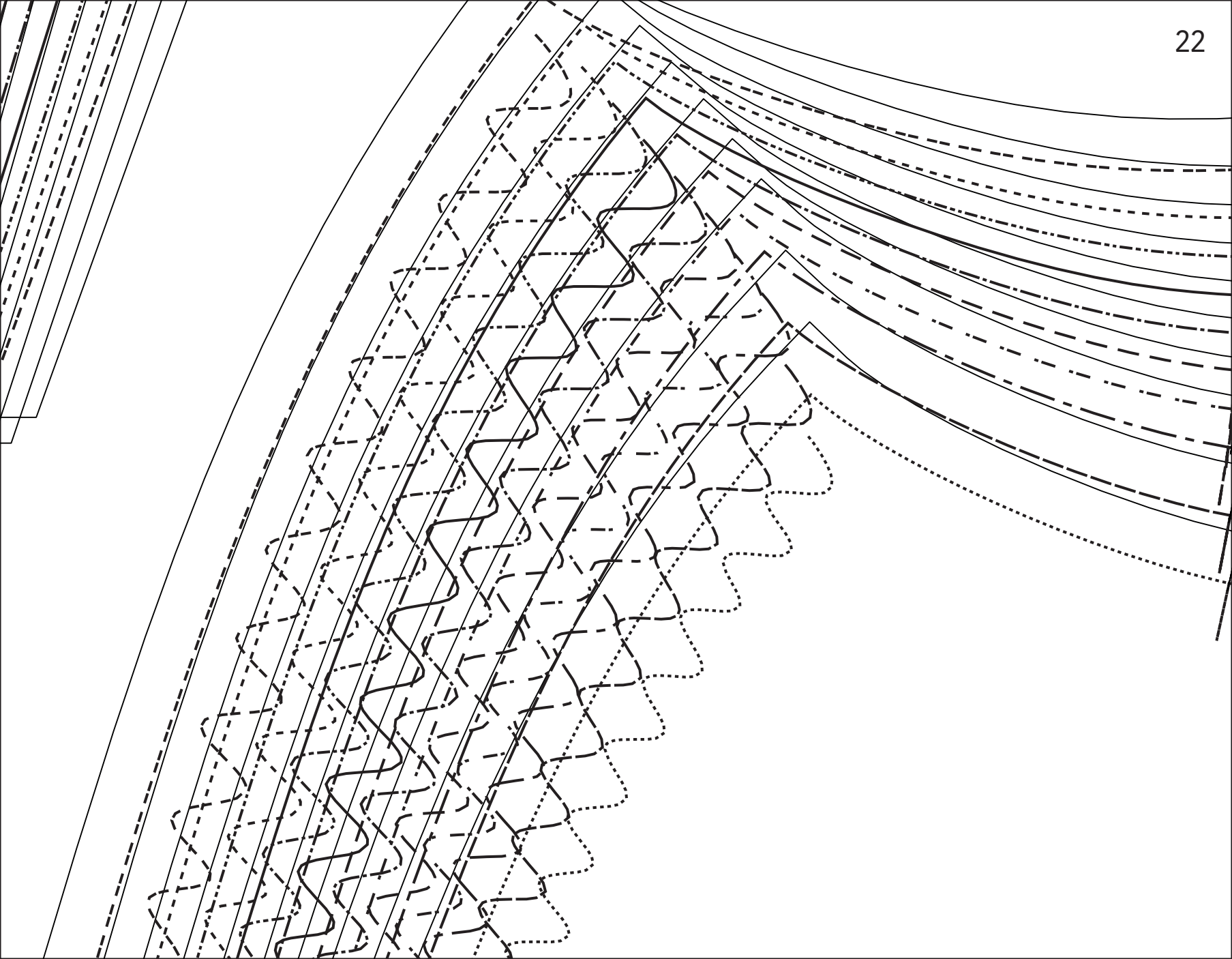

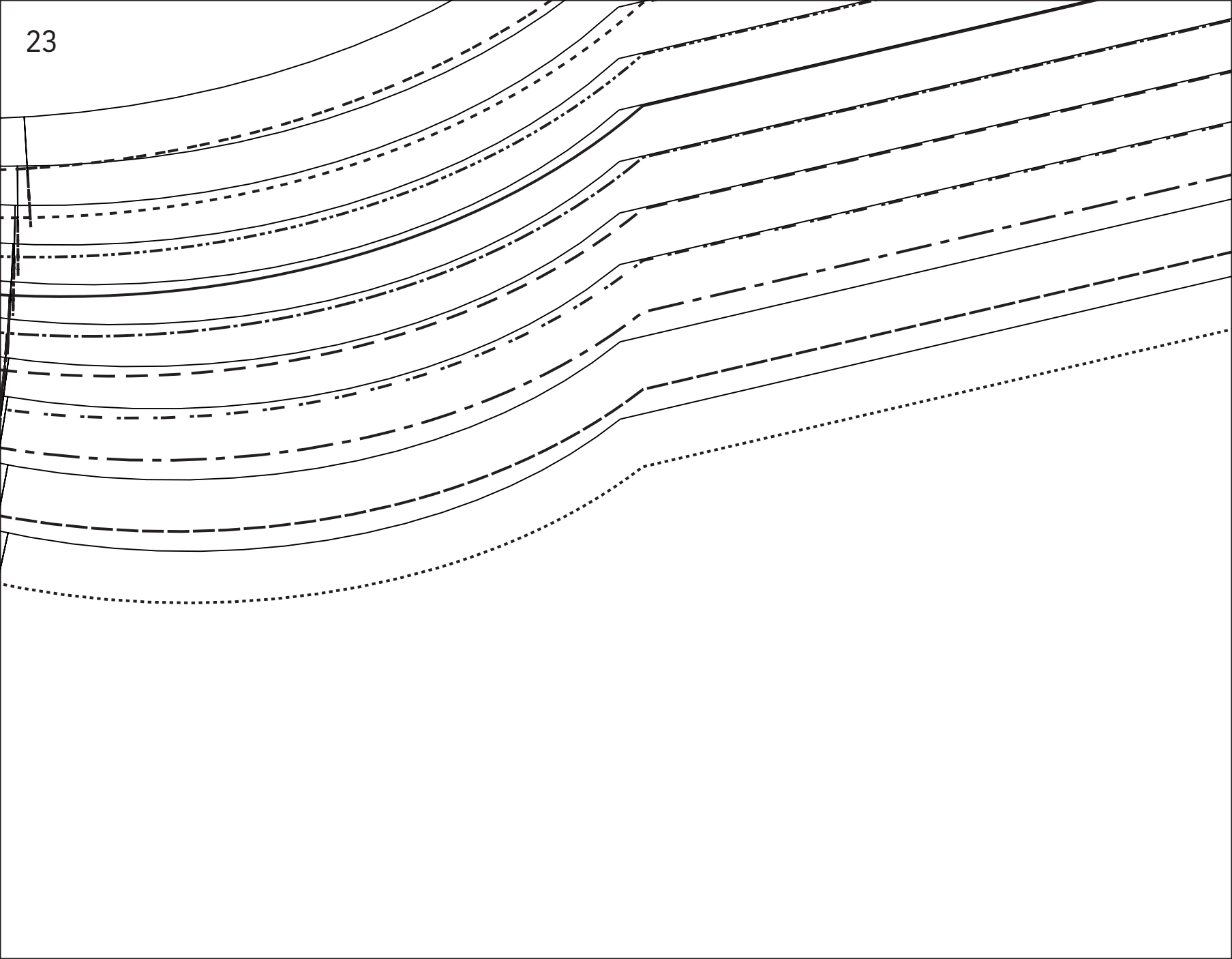

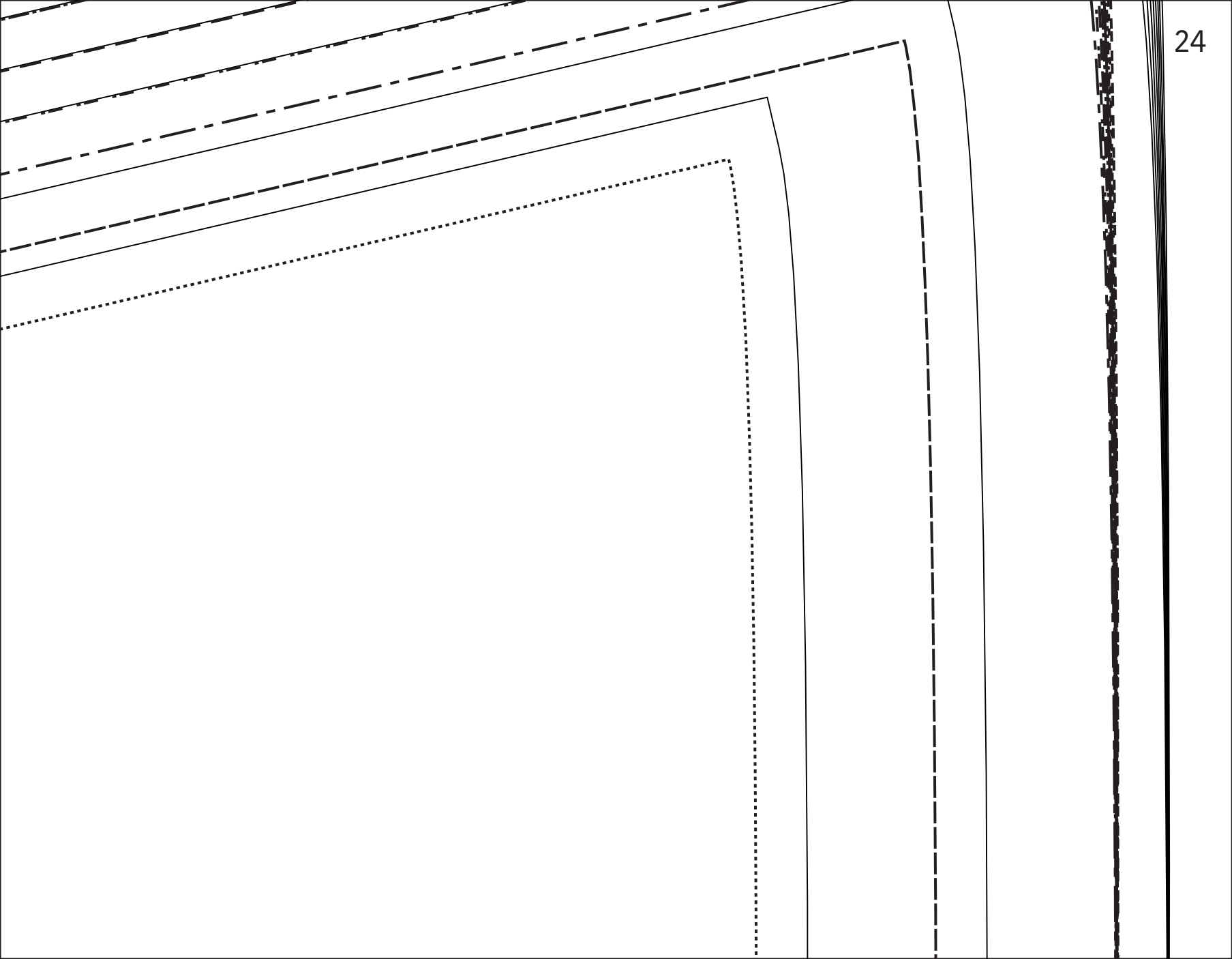

MV/MDV/CF/VM



MR/MDS/CB/RM

C

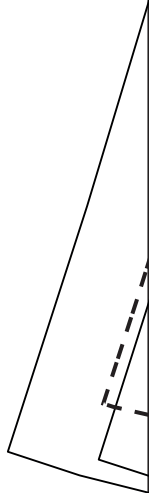

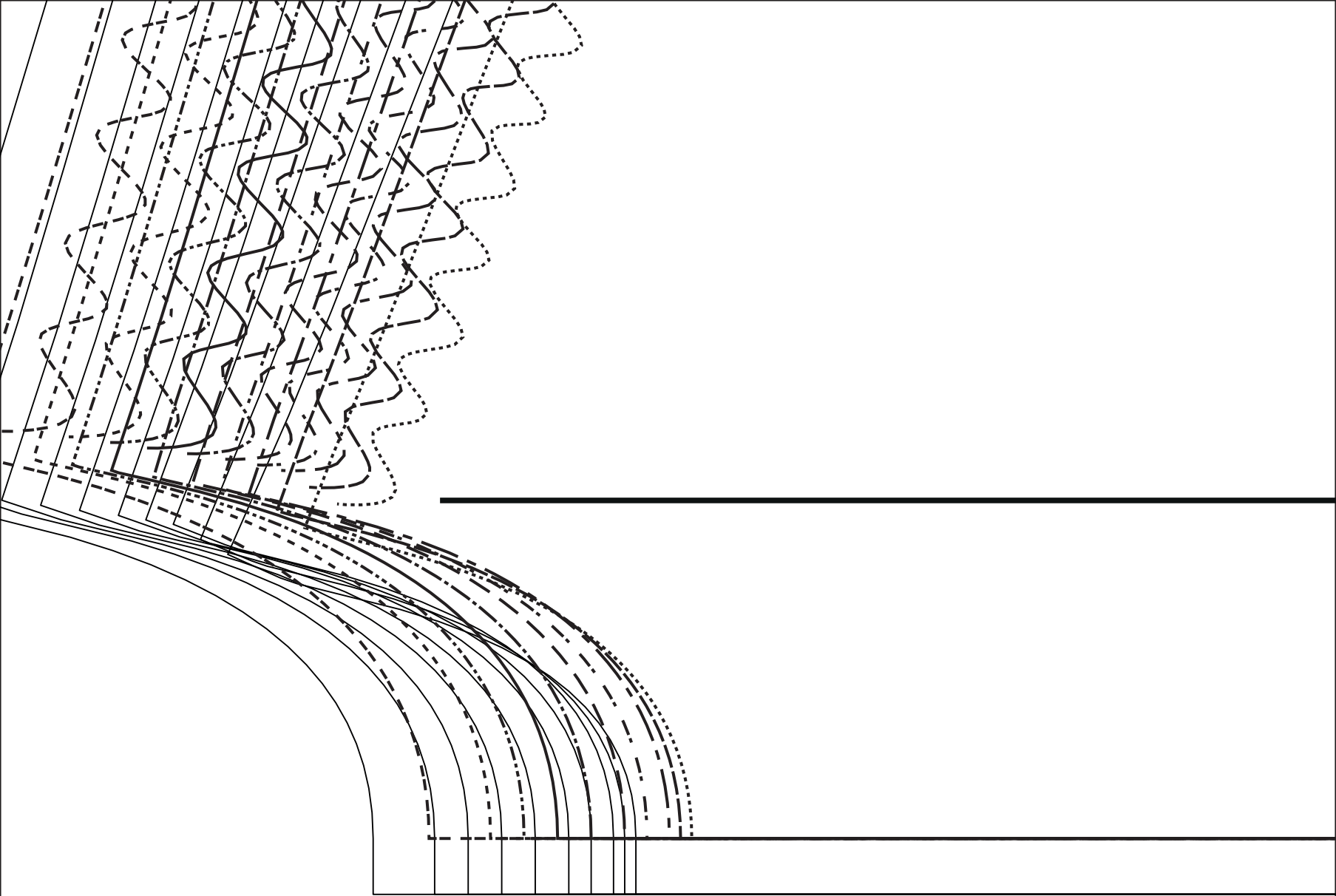

A



MV/MDV/CF/VM

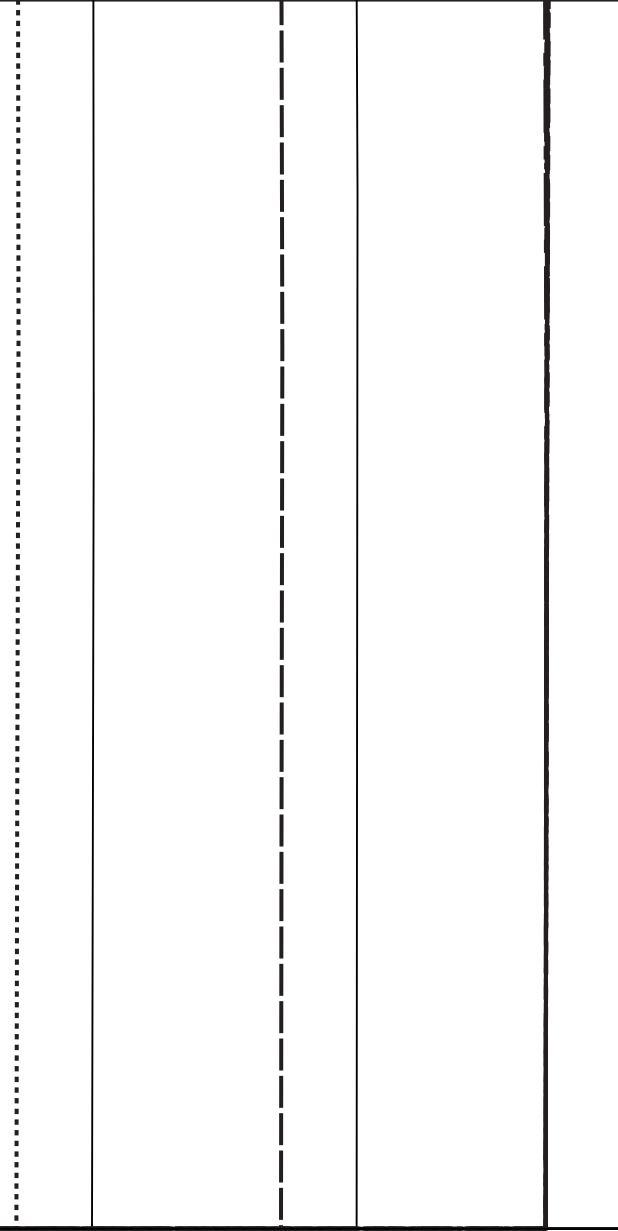



Handwriting practice lines consisting of two sets of horizontal lines. Each set includes a solid top line, a dashed middle line, and a solid bottom line.

