

# Maxime

## Blouse

### Maten / Tailles / Sizes:

|           |    |
|-----------|----|
| -----     | 34 |
| - - - - - | 36 |
| -----     | 38 |
| - - - - - | 40 |
| =====     | 42 |
| -----     | 44 |
| - - - - - | 46 |
| -----     | 48 |
| - - - - - | 50 |
| -----     | 52 |
| - - - - - | 54 |
| -----     | 56 |

### Patroondelen / Pièces du patron / Pattern pieces:

- A** voorpand / devant / front panel
- B** rugpand / dos / back panel
- C** halsstuk VP / empiècement encolure  
DV / yoke FP
- D** halsstuk RP / empiècement encolure  
DS / yoke BP
- E** mouwboord / bord manchetten / cuff
- F** zoomboord / liseré ourlet / hem trim
- G** halsboord / liseré de l'encolure /  
neck trim

### Patroonschema / Schéma du Patron / Pattern Diagram / Übersichtsplan zum Zusammenkleben

|    |    |    |    |    |    |
|----|----|----|----|----|----|
| 1  | 2  | 3  | 4  | 5  | 6  |
| 7  | 8  | 9  | 10 | 11 | 12 |
| 13 | 14 | 15 | 16 | 17 | 18 |
| 19 | 20 | 21 | 22 | 23 | 24 |
| 25 | 26 | 27 | 28 | 29 |    |

### Controlevierkant / Carré de controle / Test square / Kontrollquadrat

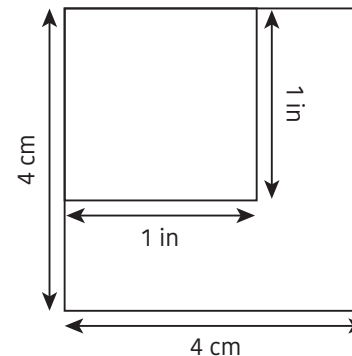

# Maxime - E

*Victor*  
LA MAISON

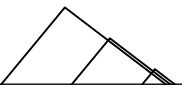
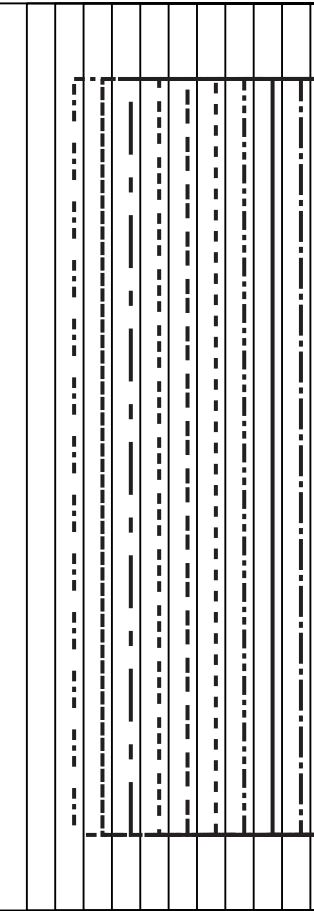

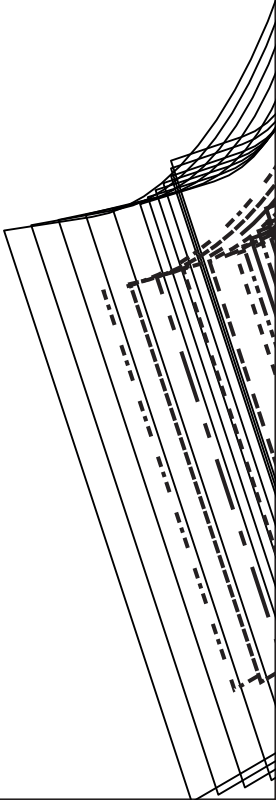
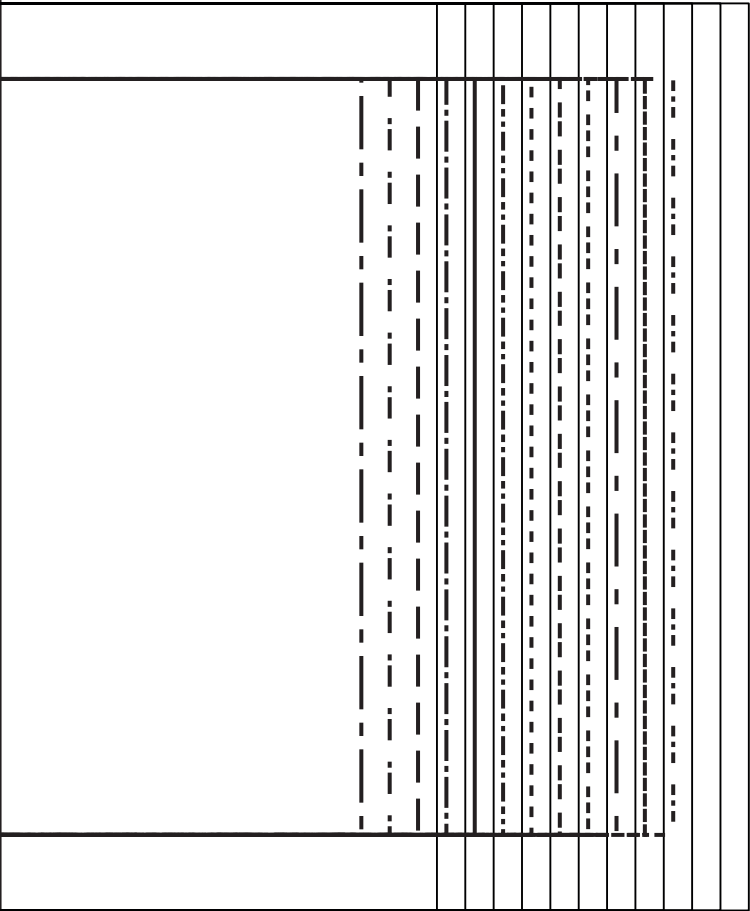

MR/MDS/CB



# Maxime - D



*Victor*  
LA MAISON

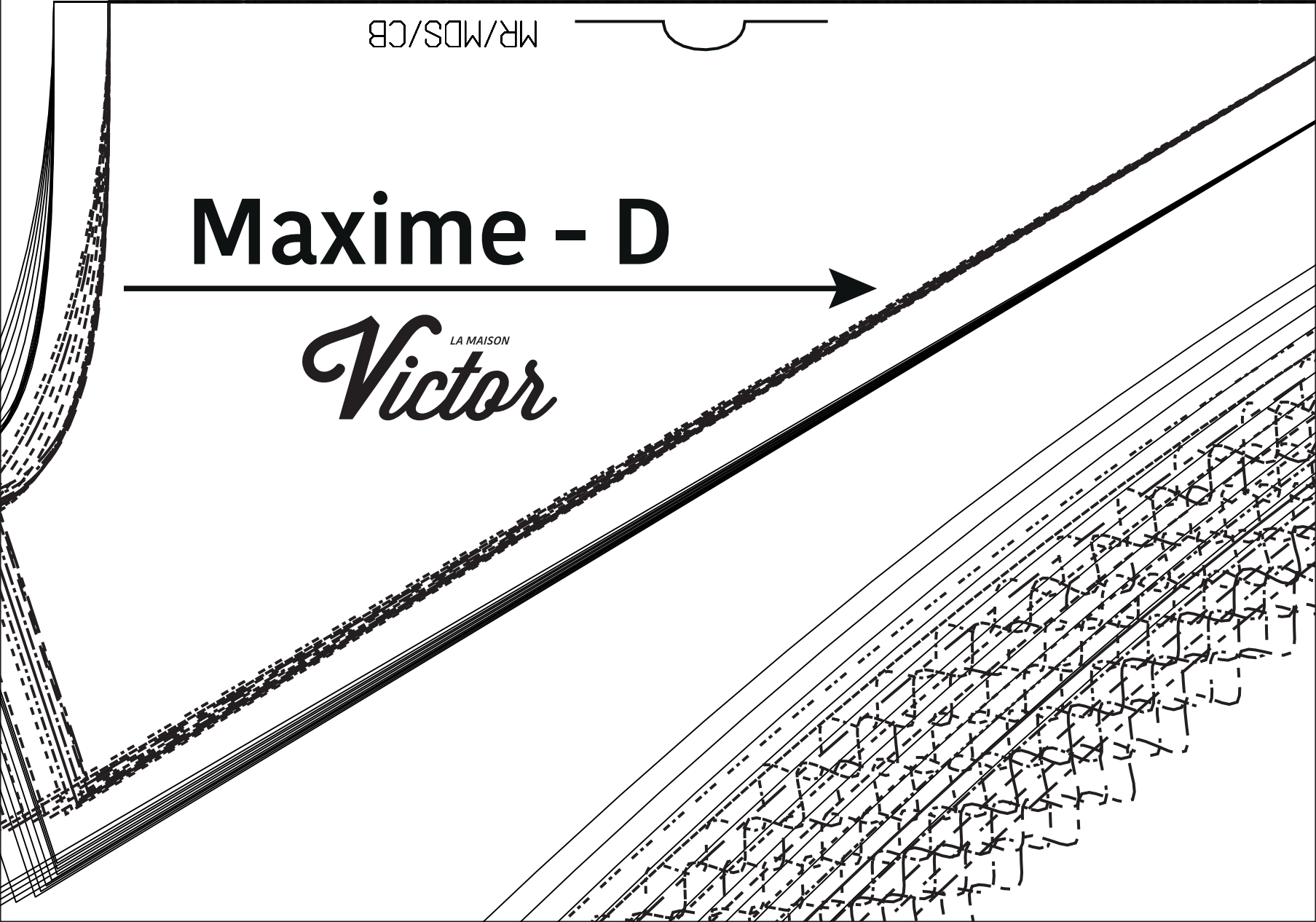

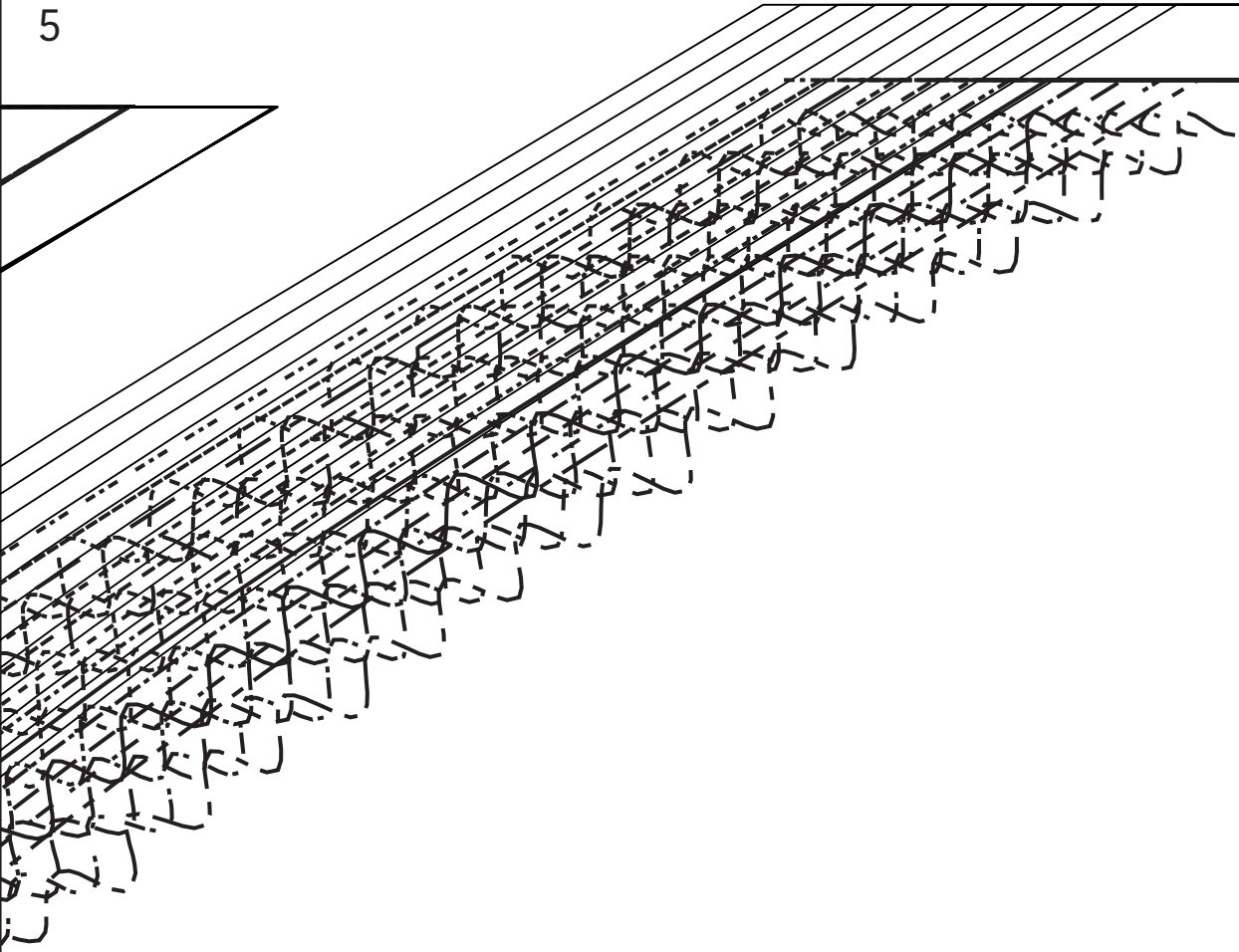

MR/MDS/CB

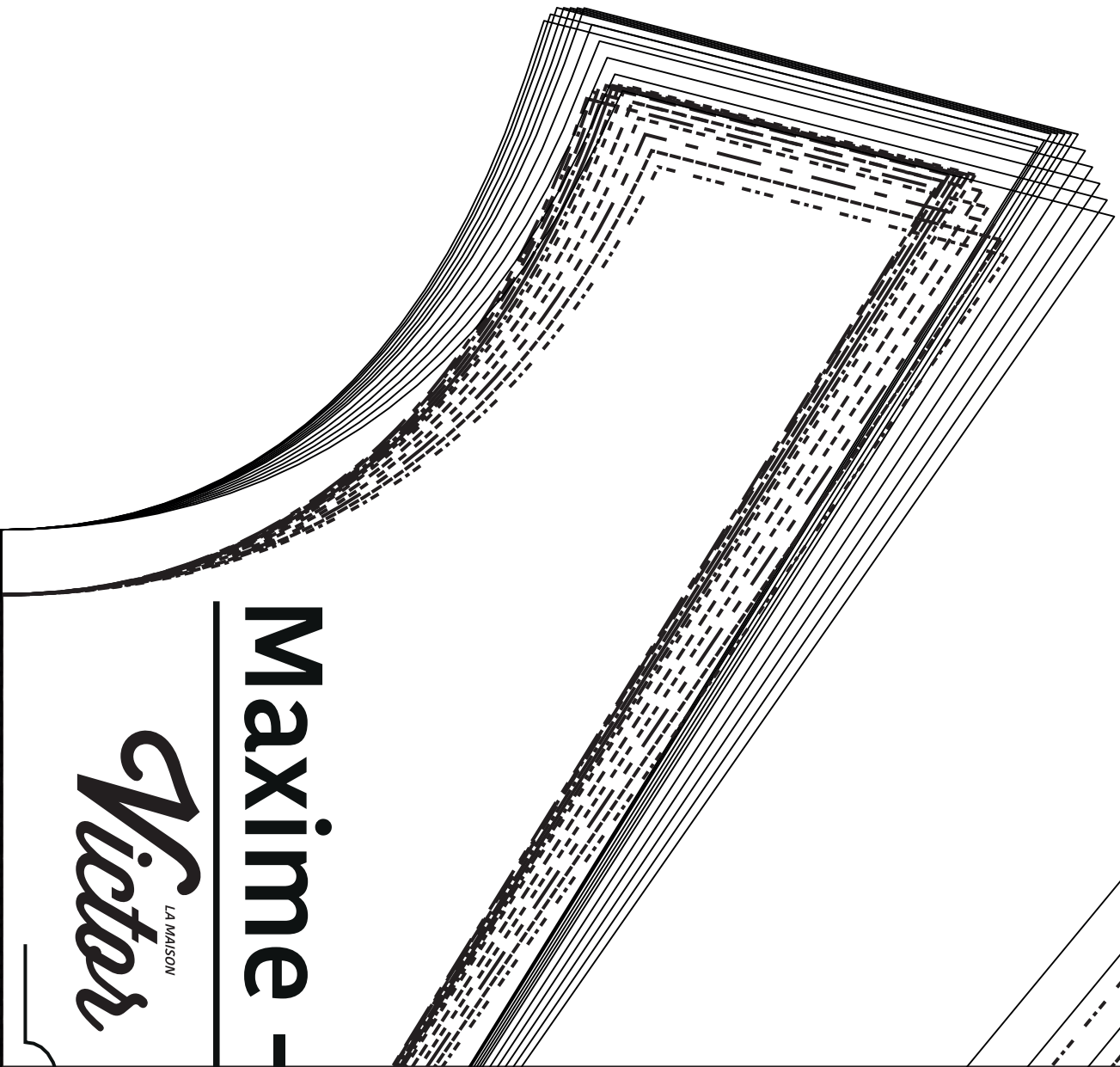

**Maxime**

*Victor*  
LA MAISON

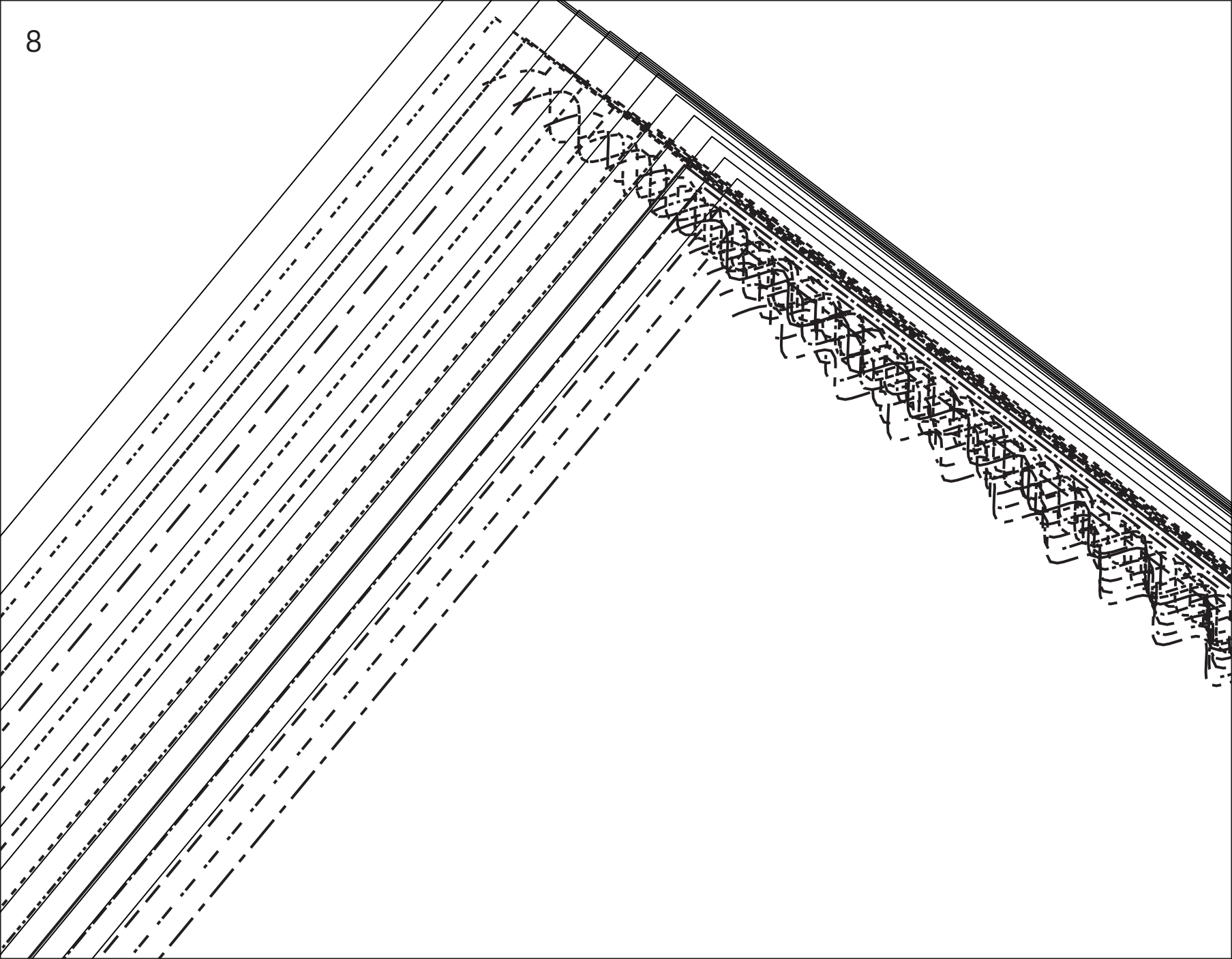



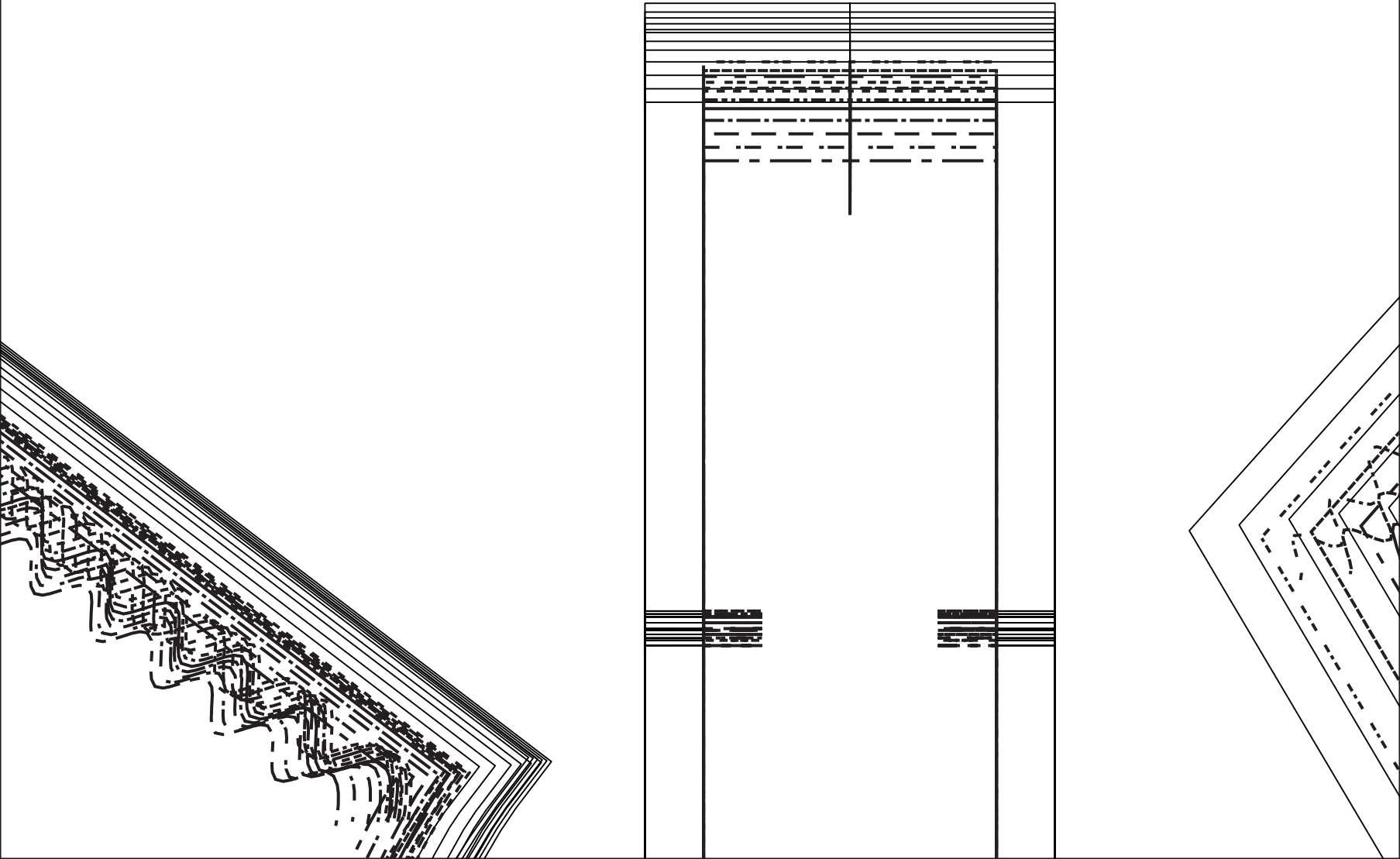

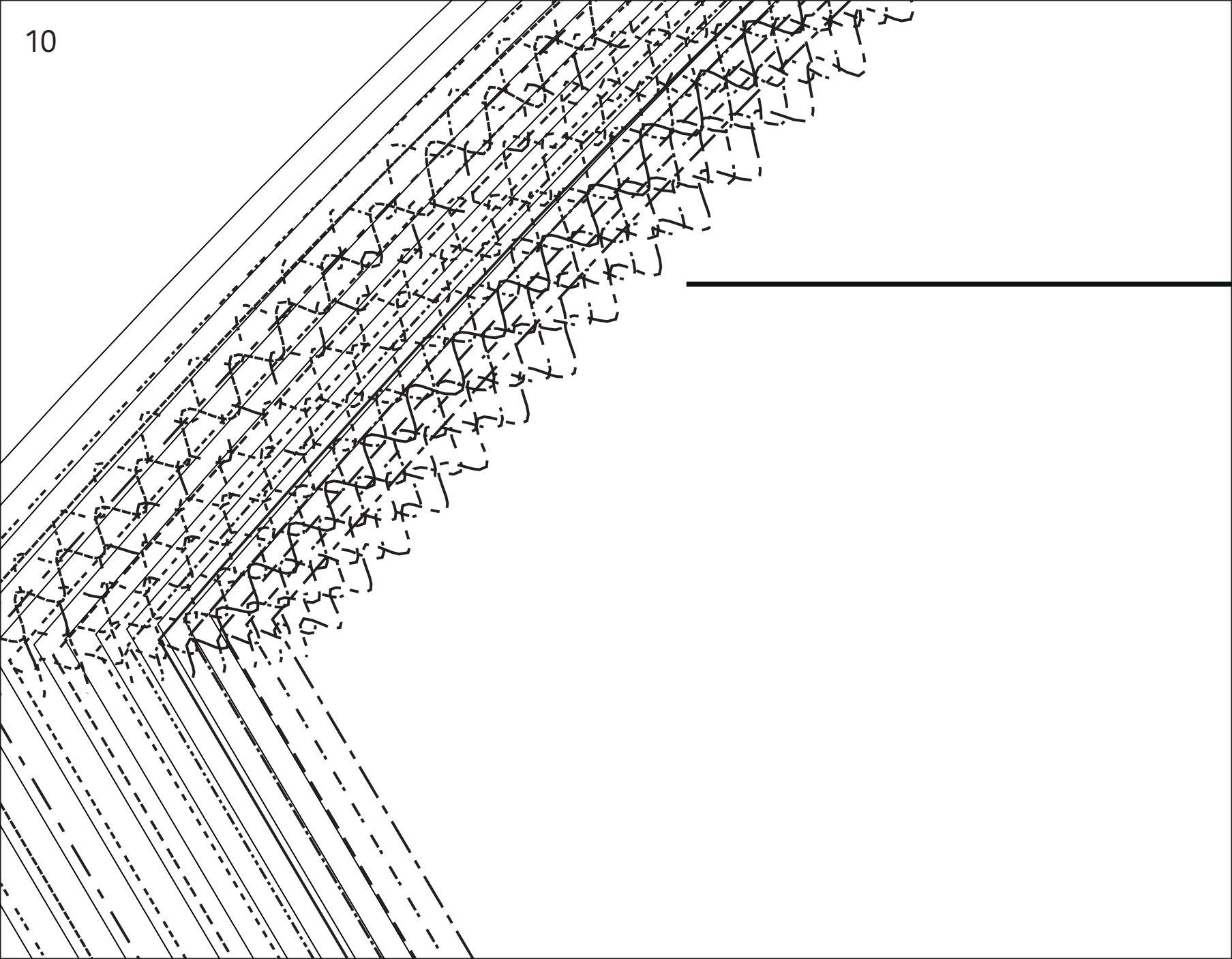

# Maxime - B

LA MAISON  
*Victor*

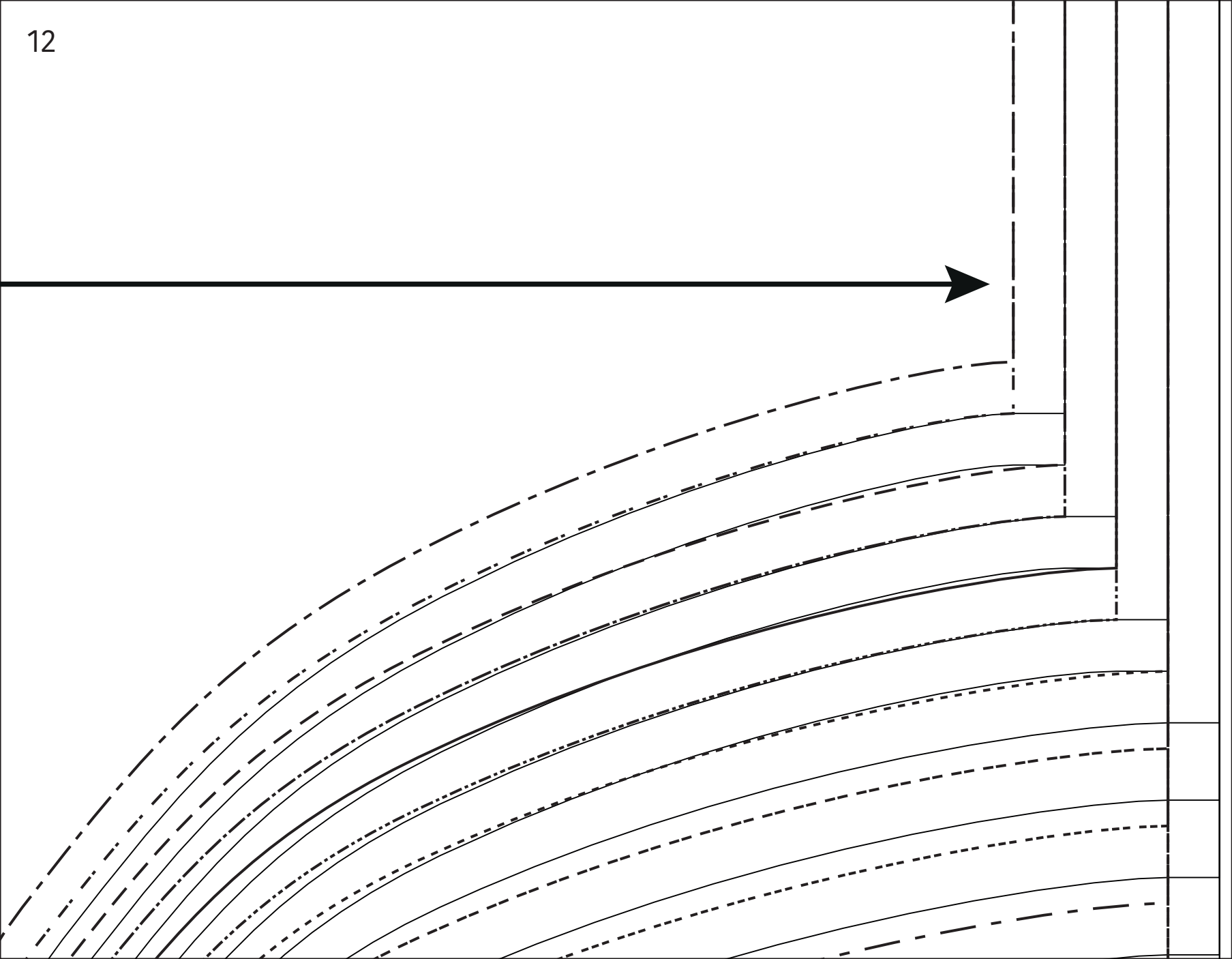

MV/MDV/CF

C

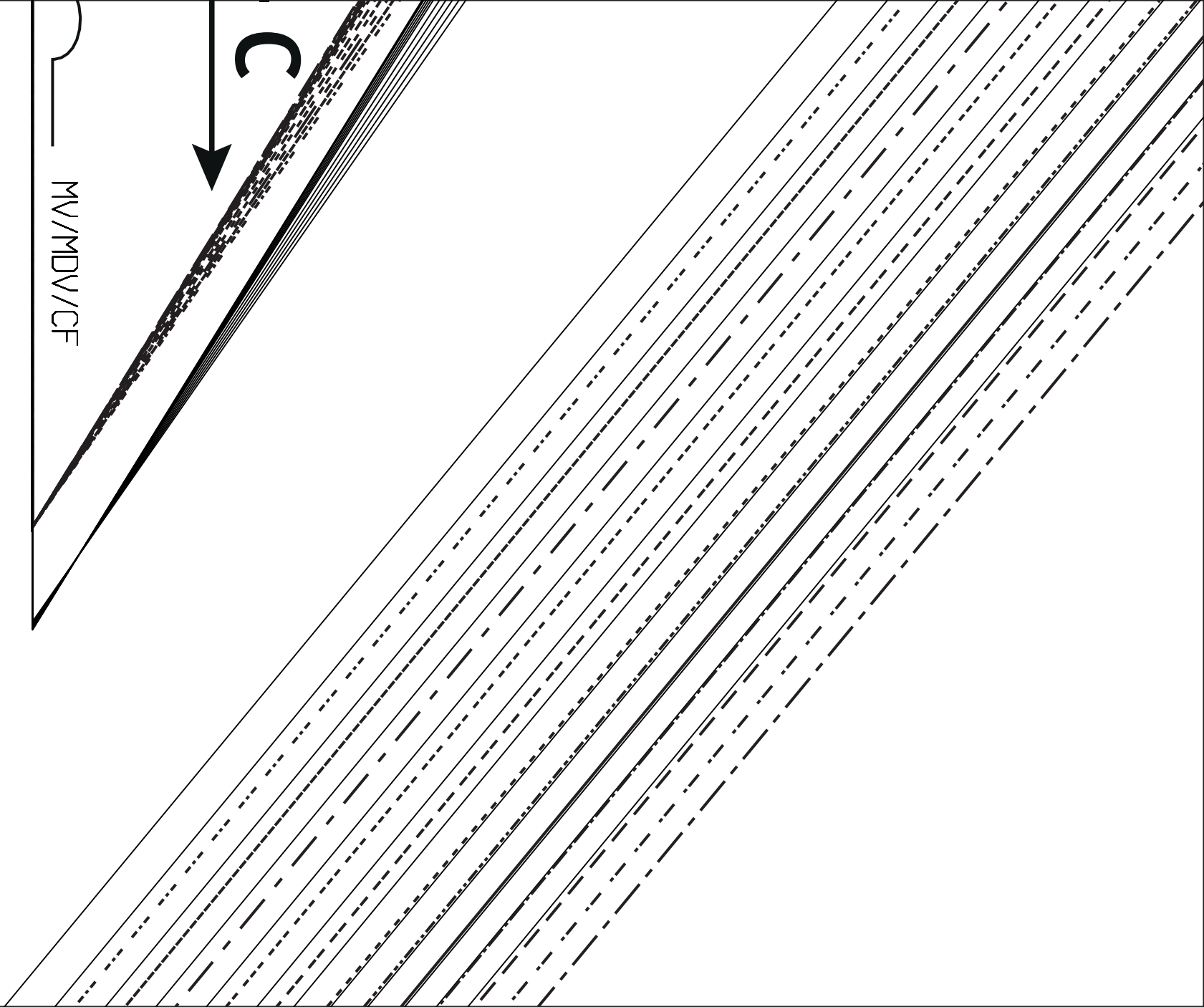

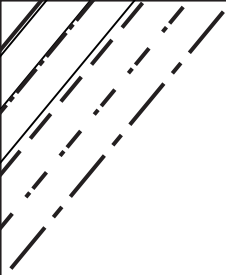

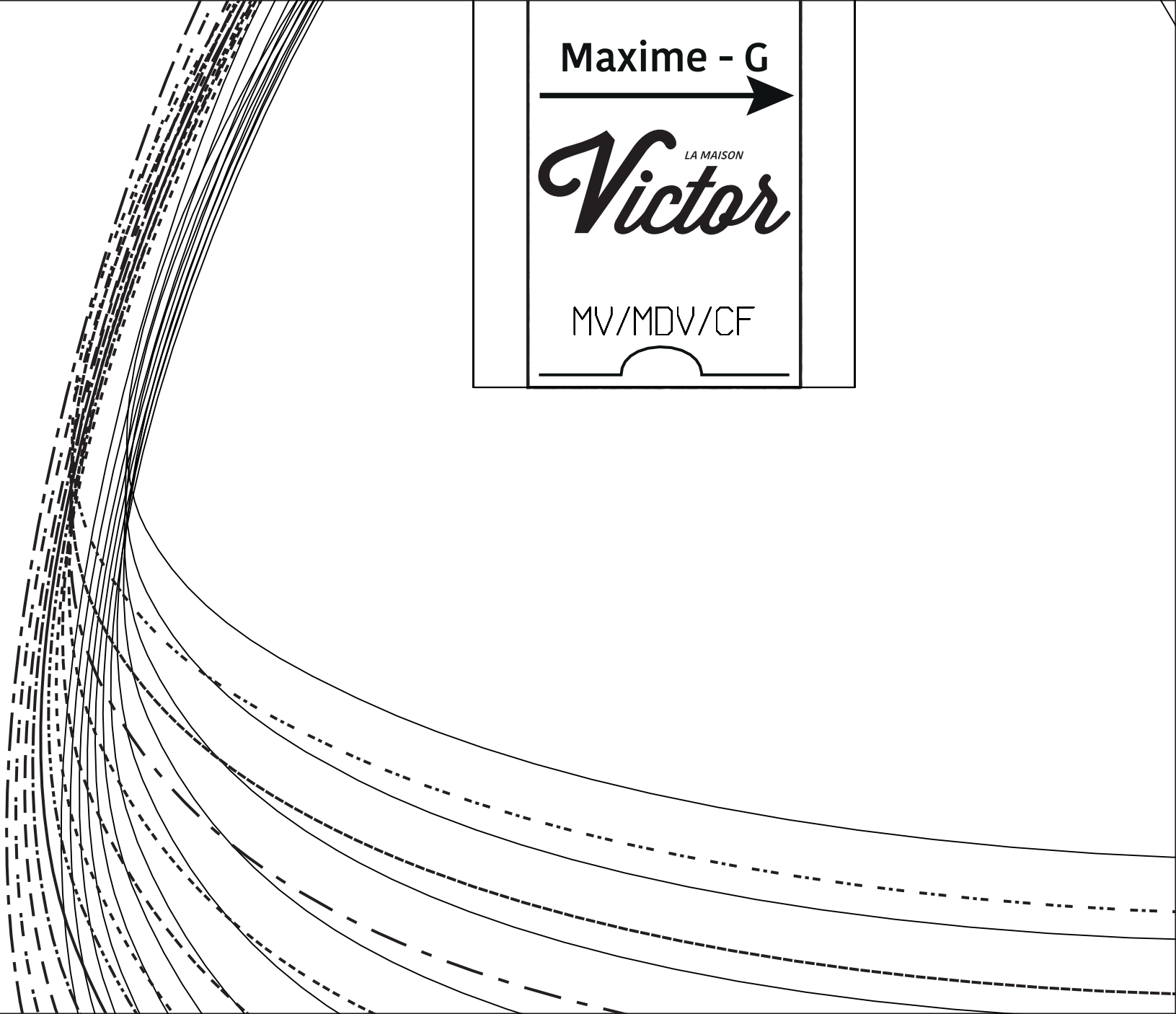

Maxime - G



*Victor*

LA MAISON

MV/MDV/CF



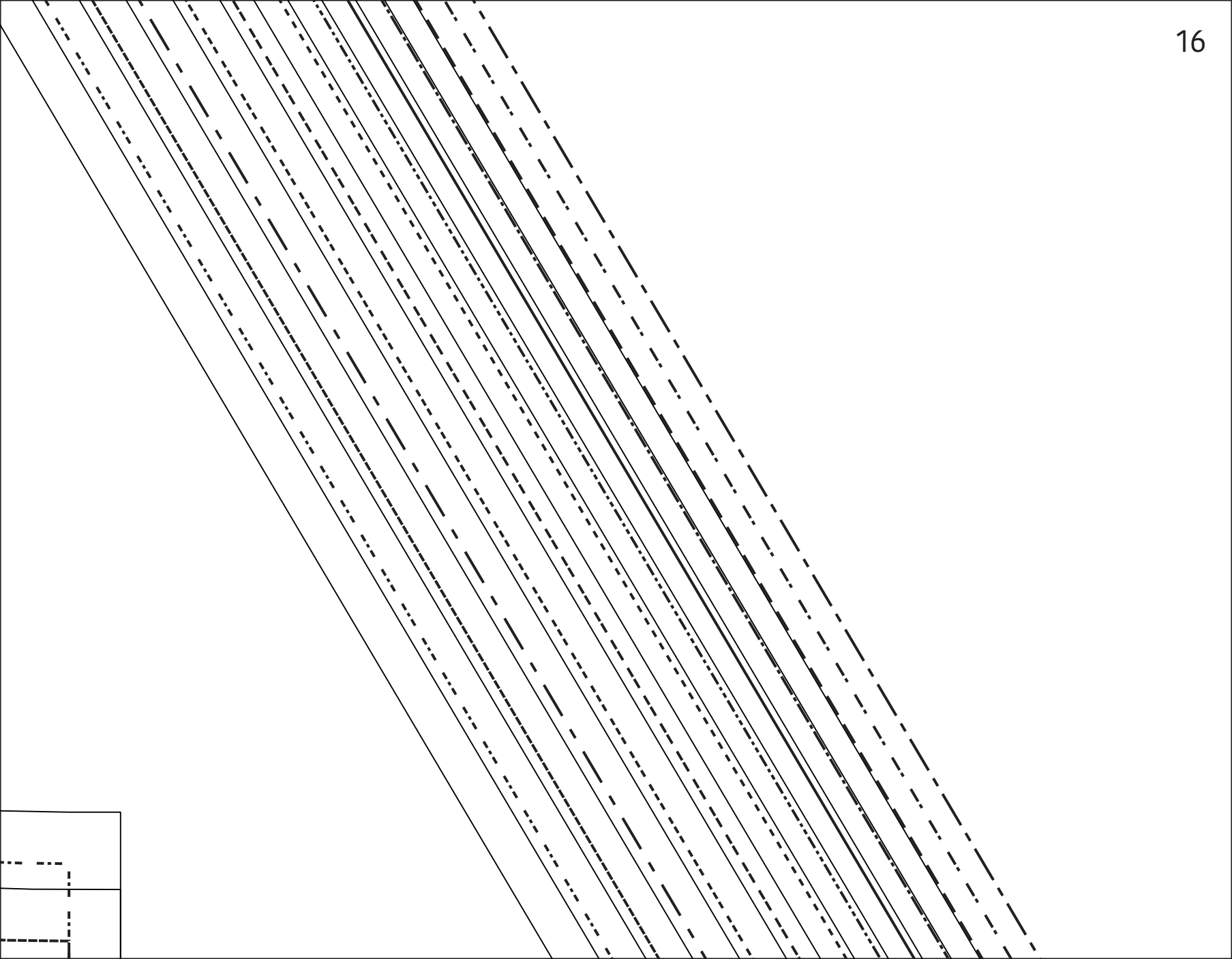



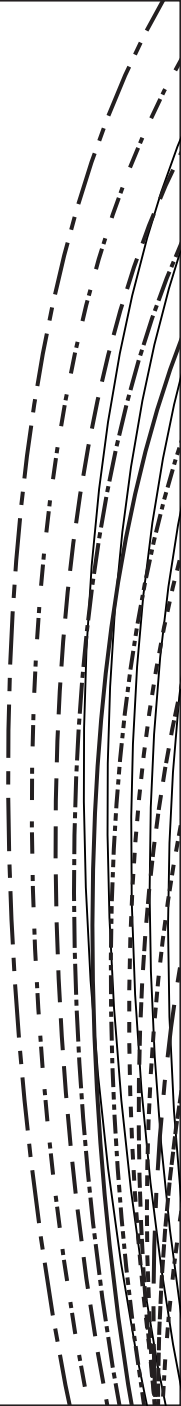

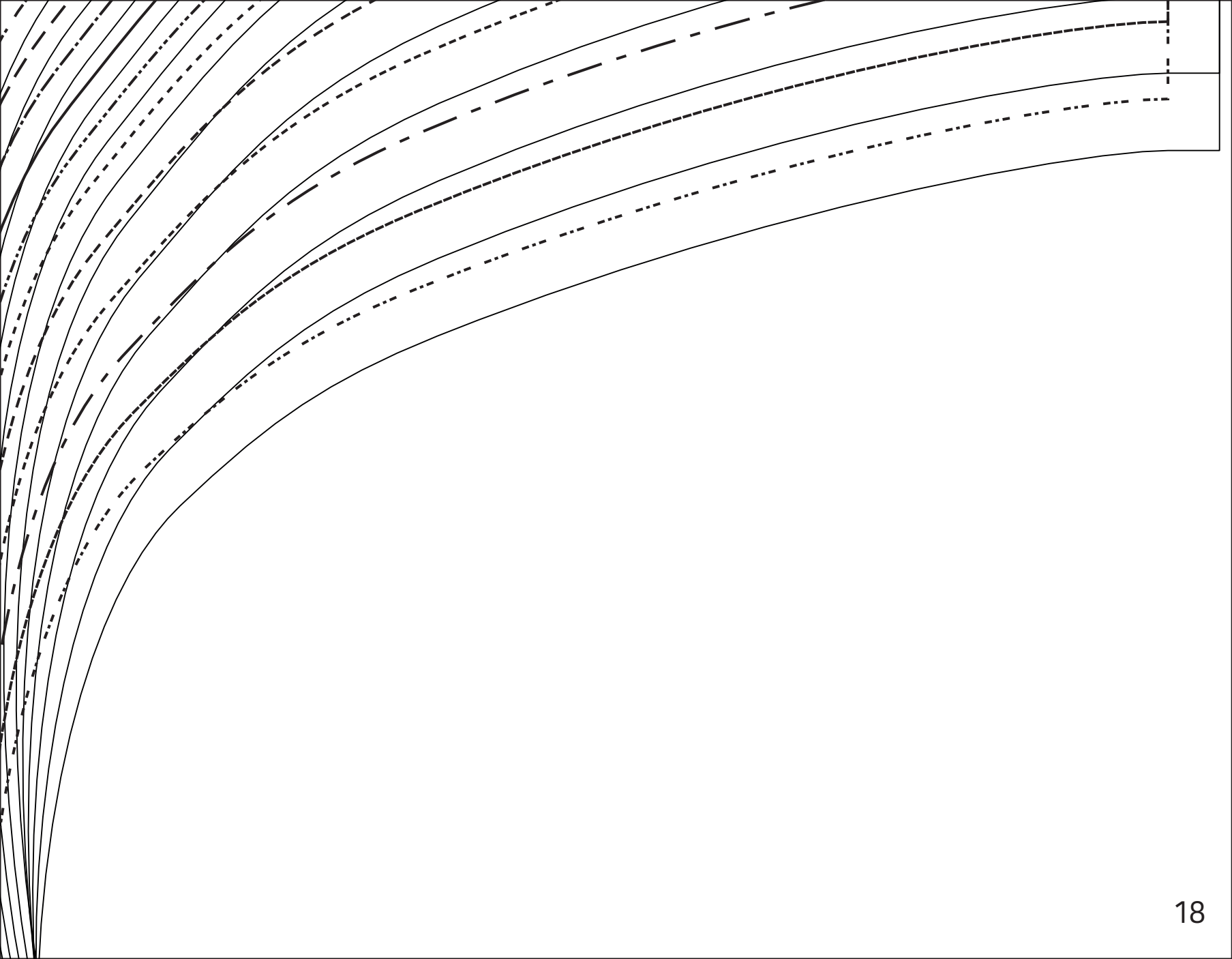

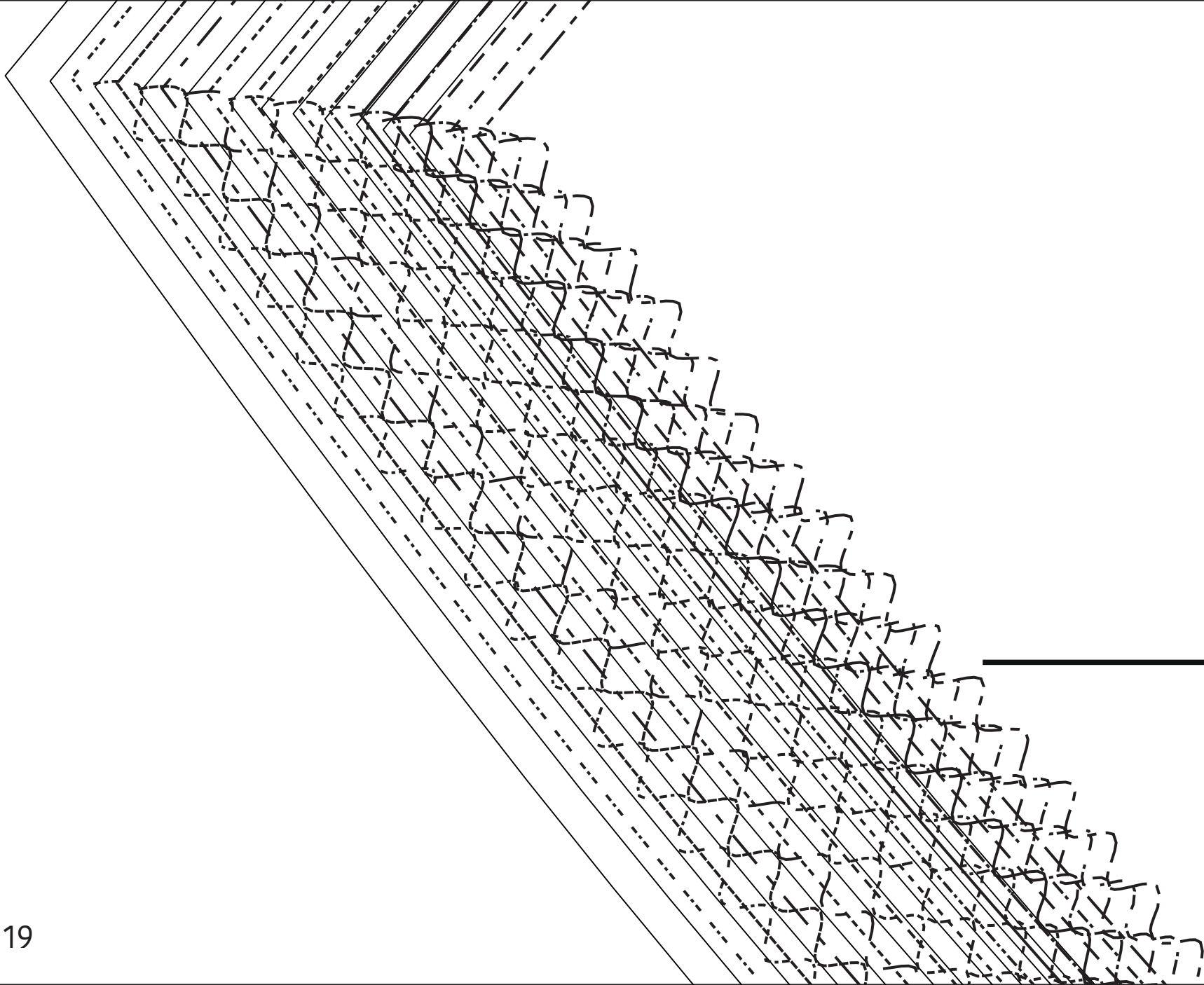

**Maxime - A**

*Victor*  
LA MAISON

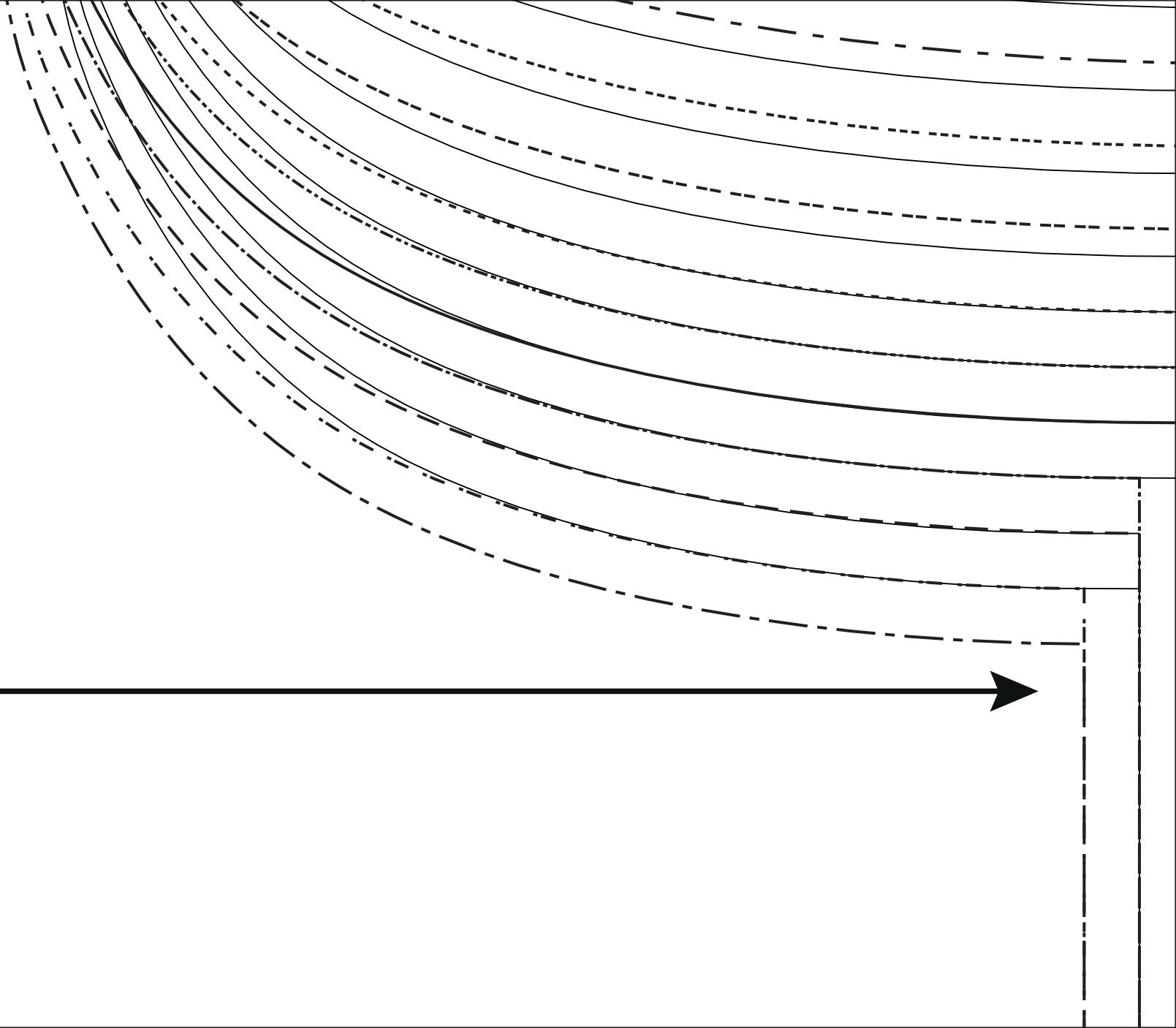

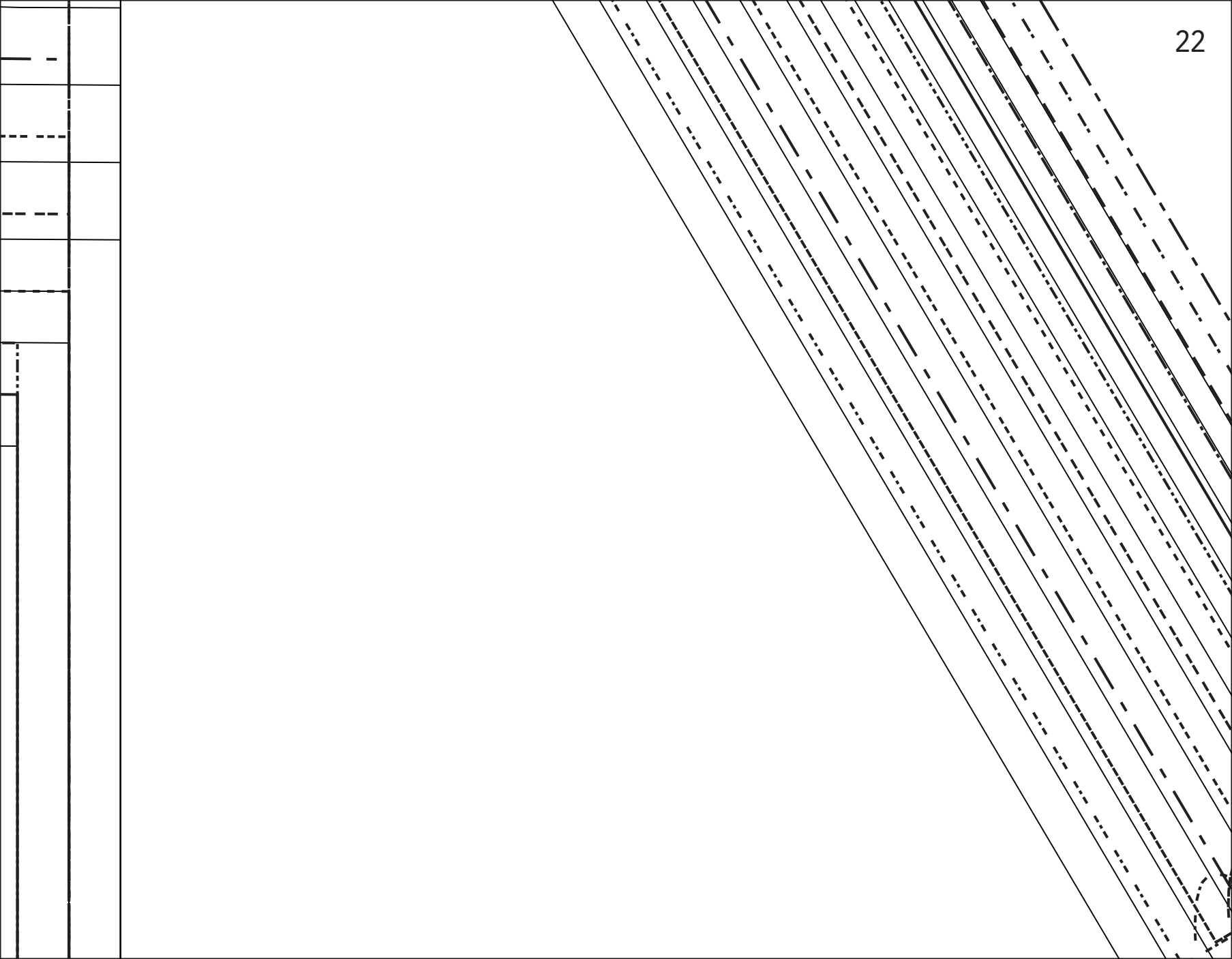

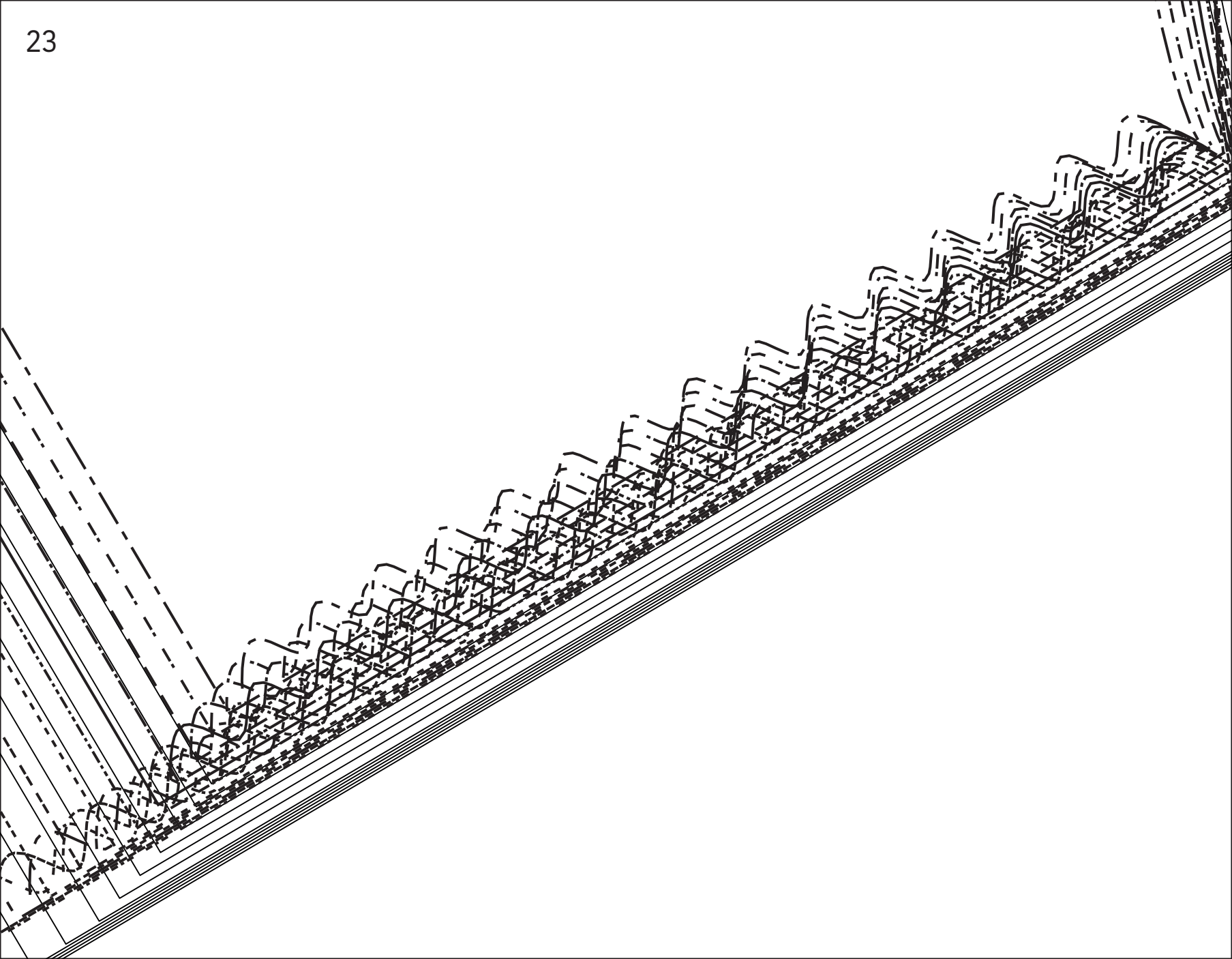

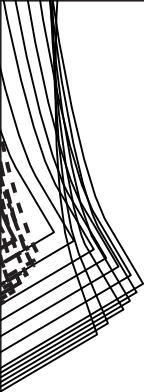



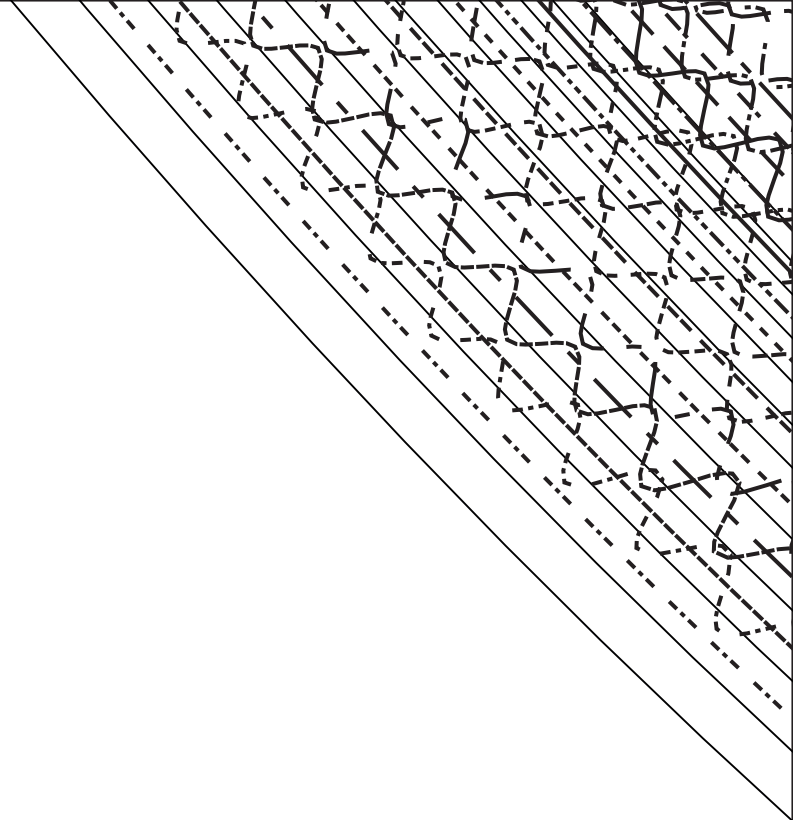

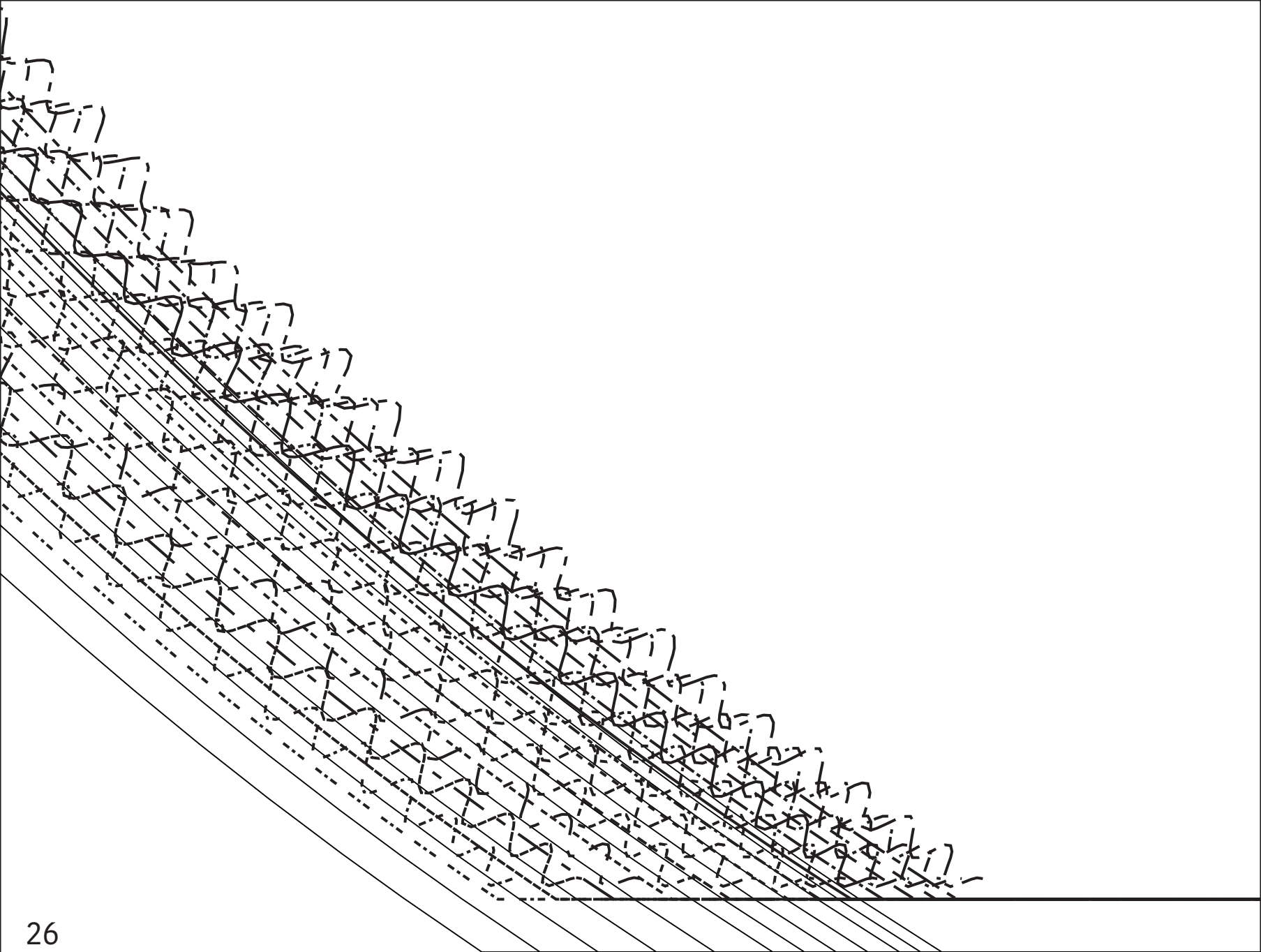

MV/MDV/CF

**Maxime - F**

*Victor*  
LA MAISON

MV/MDV/CF

MR/MDS/CB

|   |     |  |       |         |   |   |   |   |   |   |   |
|---|-----|--|-------|---------|---|---|---|---|---|---|---|
| - | - . |  | . . . | - . . . | - | - | - | - | - | - | - |
|   |     |  |       |         |   |   |   |   |   |   |   |