

Linna

Mantel / Manteau / Coat

Maten / Tailles / Sizes / Größen:

-----	34
-----	36
-----	38
-----	40
—————	42
-----	44
-----	46
-----	48
-----	50
-----	52
-----	54
-----	56

Patroonschema / Schéma du Patron / Pattern Diagram /
Übersichtsplan zum Zusammenkleben

1	2	3	4	5	6	7
8	9	10	11	12	13	14
15	16	17	18	19	20	21
22	23	24	25	26	27	28
29	30	31	32	33	34	35
36	37	38	39	40	41	42
43	44	45	46	47	48	49
50	51	52	53	54	55	56
57	58	59	60	61	62	63
64	65	66	67	68	69	70
71	72	73	74	75	76	77

Controlevierkant / Carré de controle
/ Test square / Kontrollquadrat

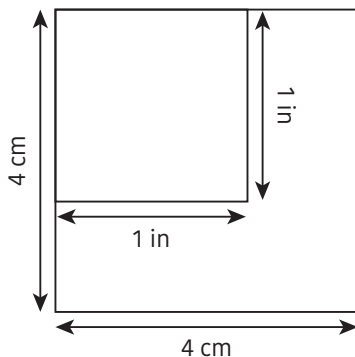

**Patroondelen / Pièces du patron /
Pattern pieces / Schnittteile:**

- A** voorpand / devant / front panel /
Vorderteil
- B** rugpand / dos / back panel /
back panel / Rückenteil
- C** beleg VP / parementure DV /
facing FP / Besatz VT
- D** beleg RP / parementure DS /
facing BP / Besatz RT
- E** bovenmouw / haut de manche /
sleeve top / oberer Ärmel
- E'** bovenmouw voering /
haut de manche doublure /
sleeve lining top /
Futter oberer Ärmel
- F** ondermouw / bas de manche /
sleeve bottom / unterer Ärmel
- F'** ondermouw voering /
bas de manche doublure /
sleeve lining bottom /
Futter unterer Ärmel
- G** zak / poche / pocket / Tasche
- H** voorpand voering / devant doublure /
front lining / Futter Vorderteil
- I** rugpand voering / dos doublure /
back lining / Futter Rückenteil

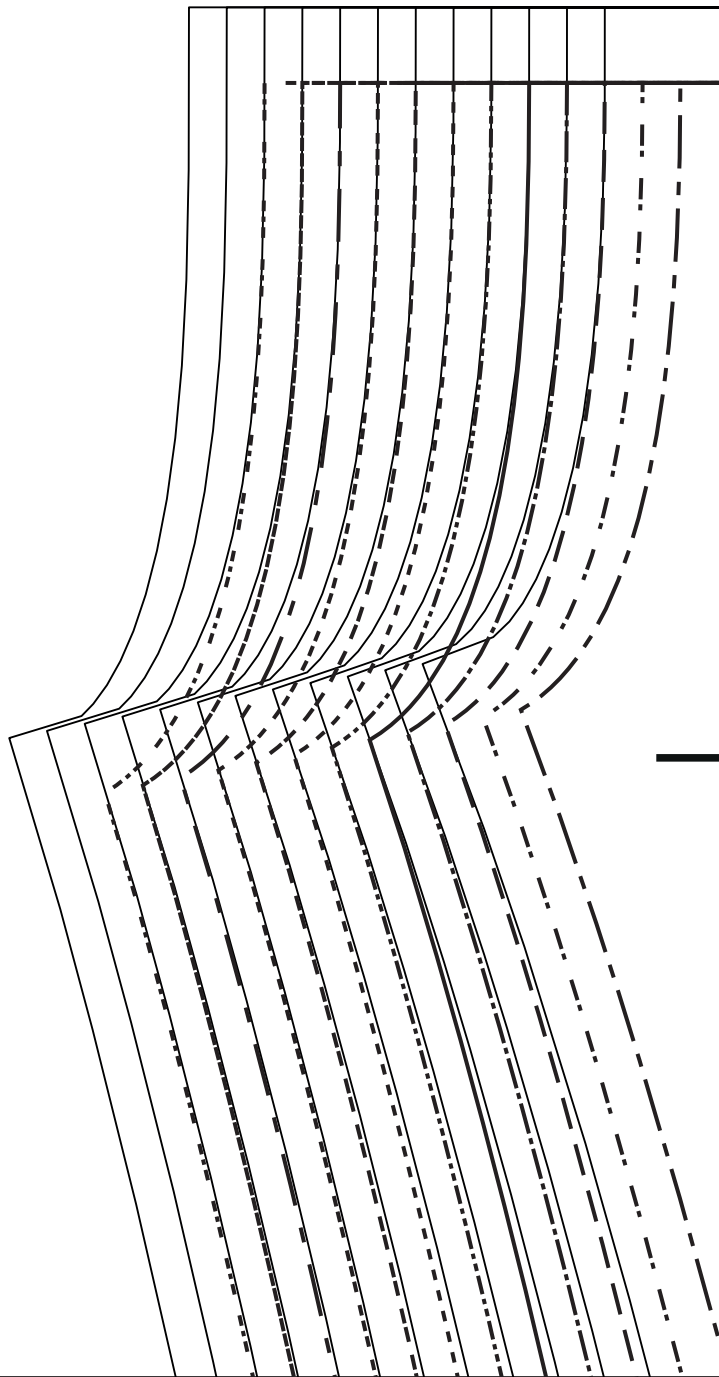

4

MR/MDS/CB/RM

5

B

7



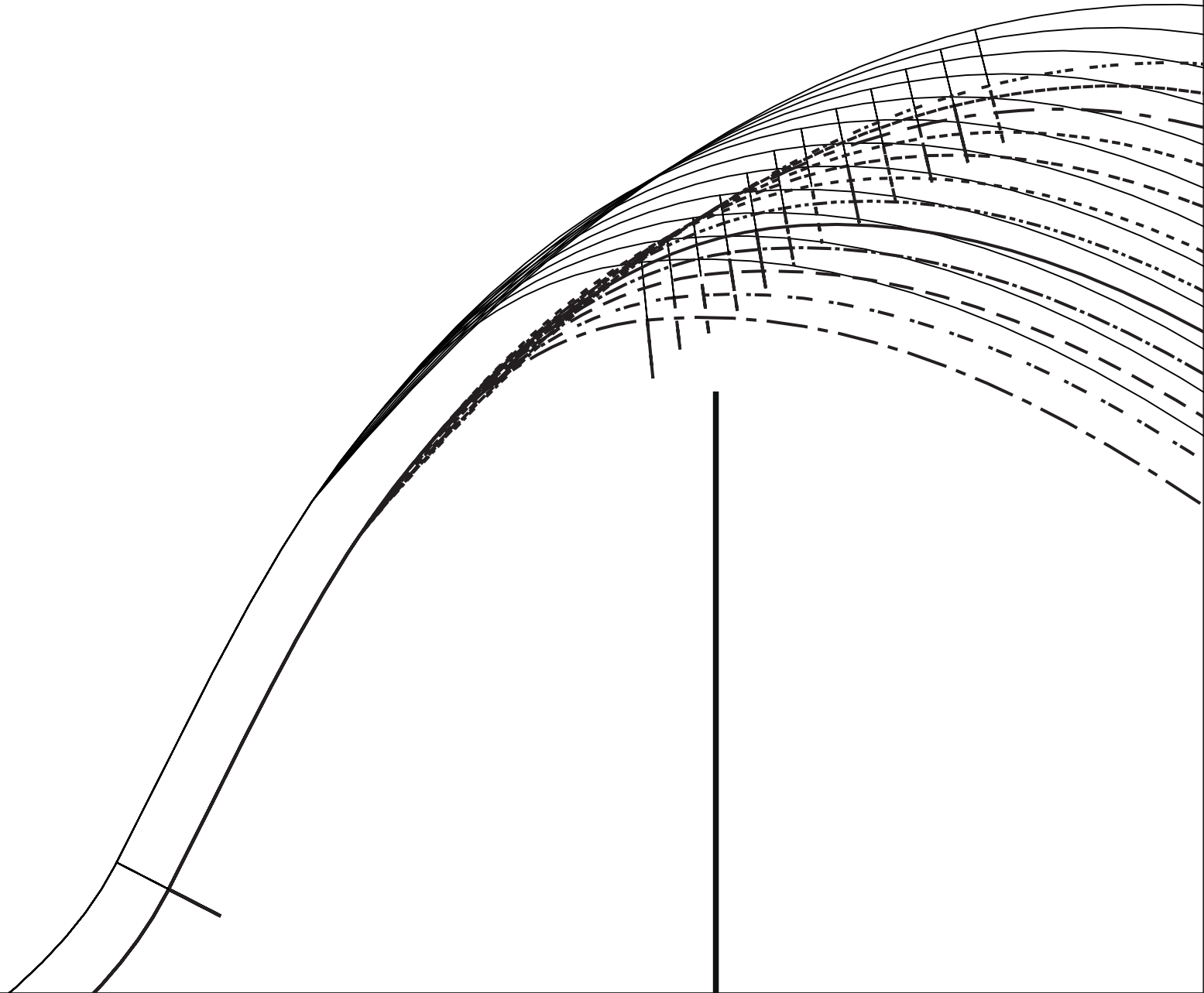

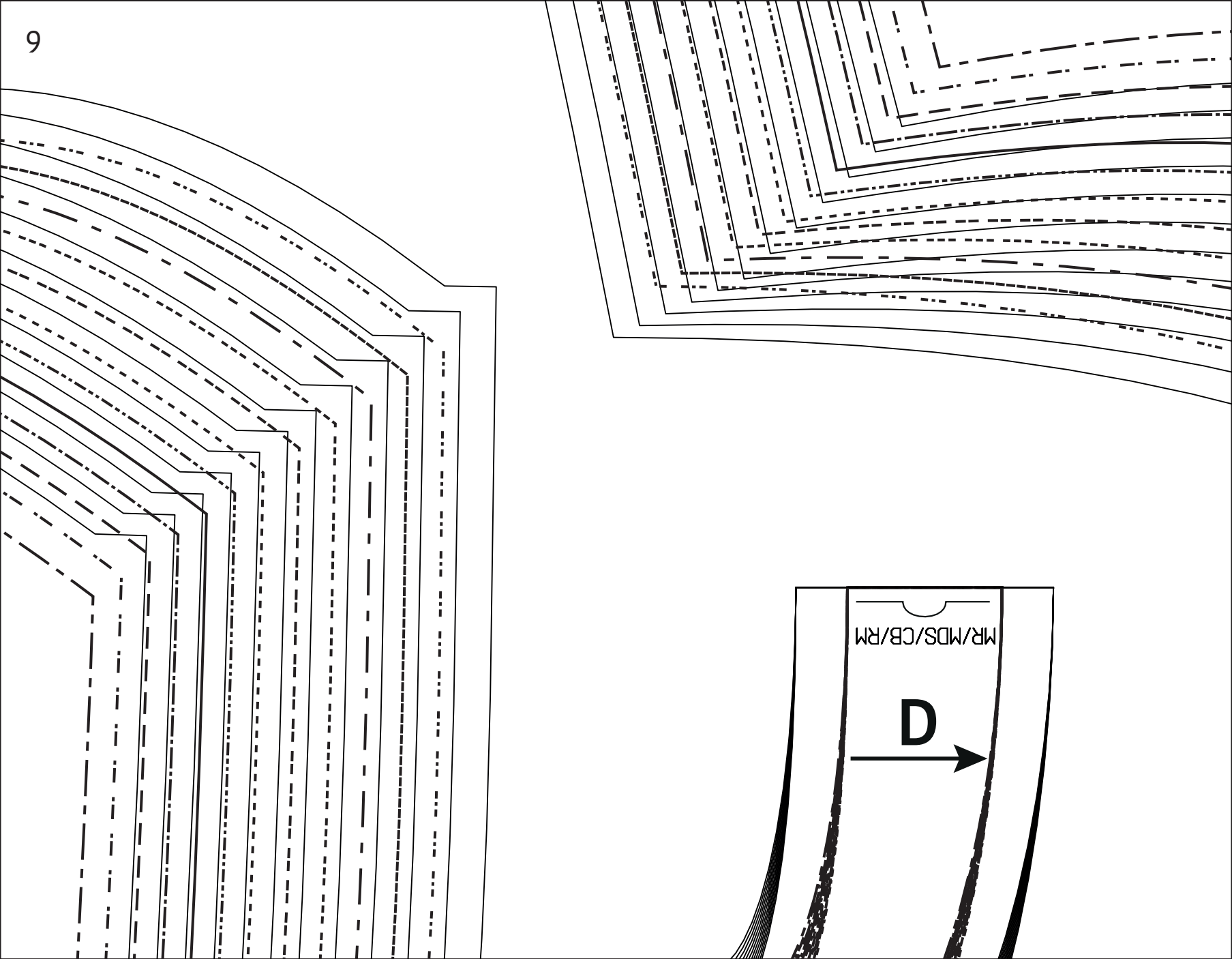

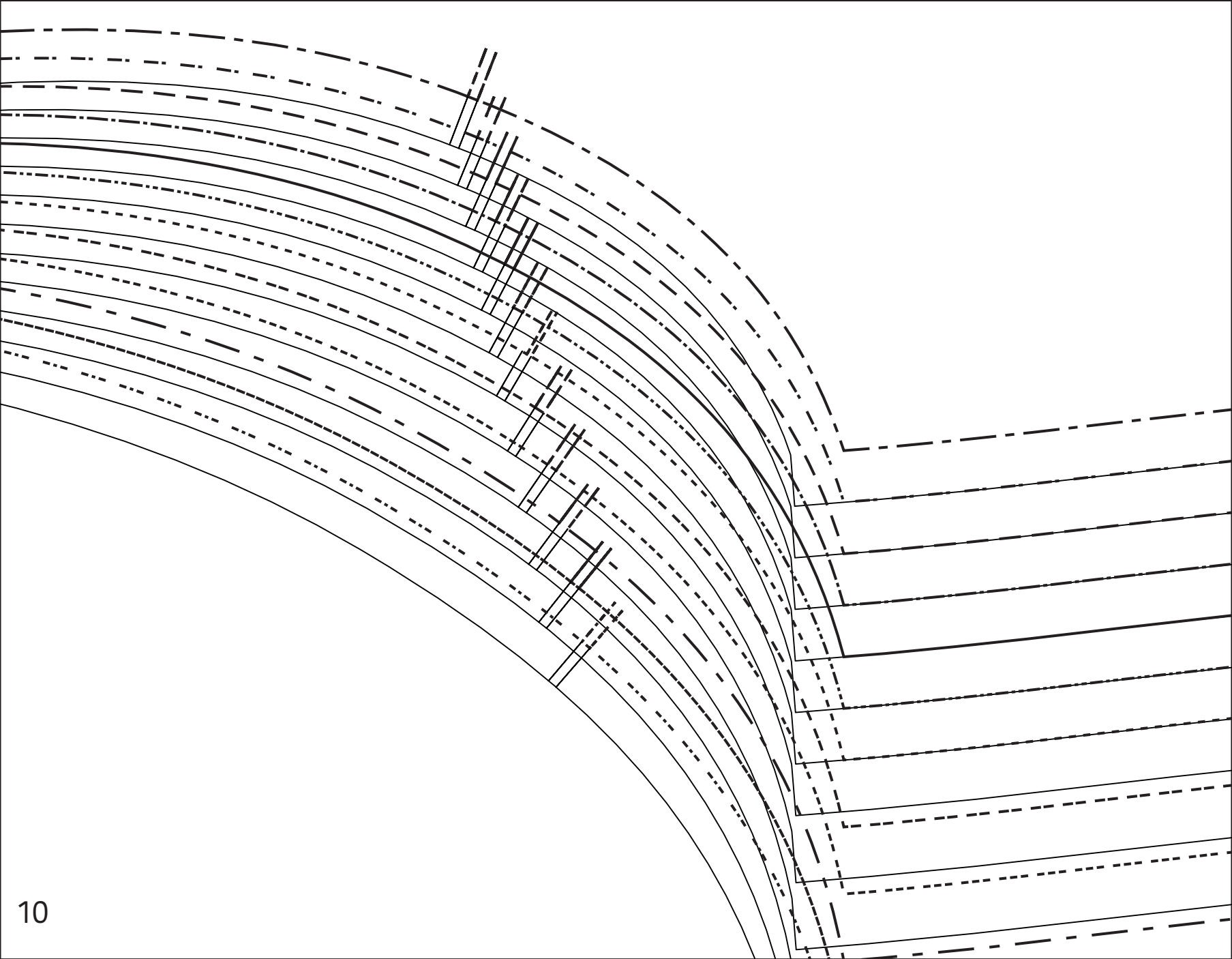

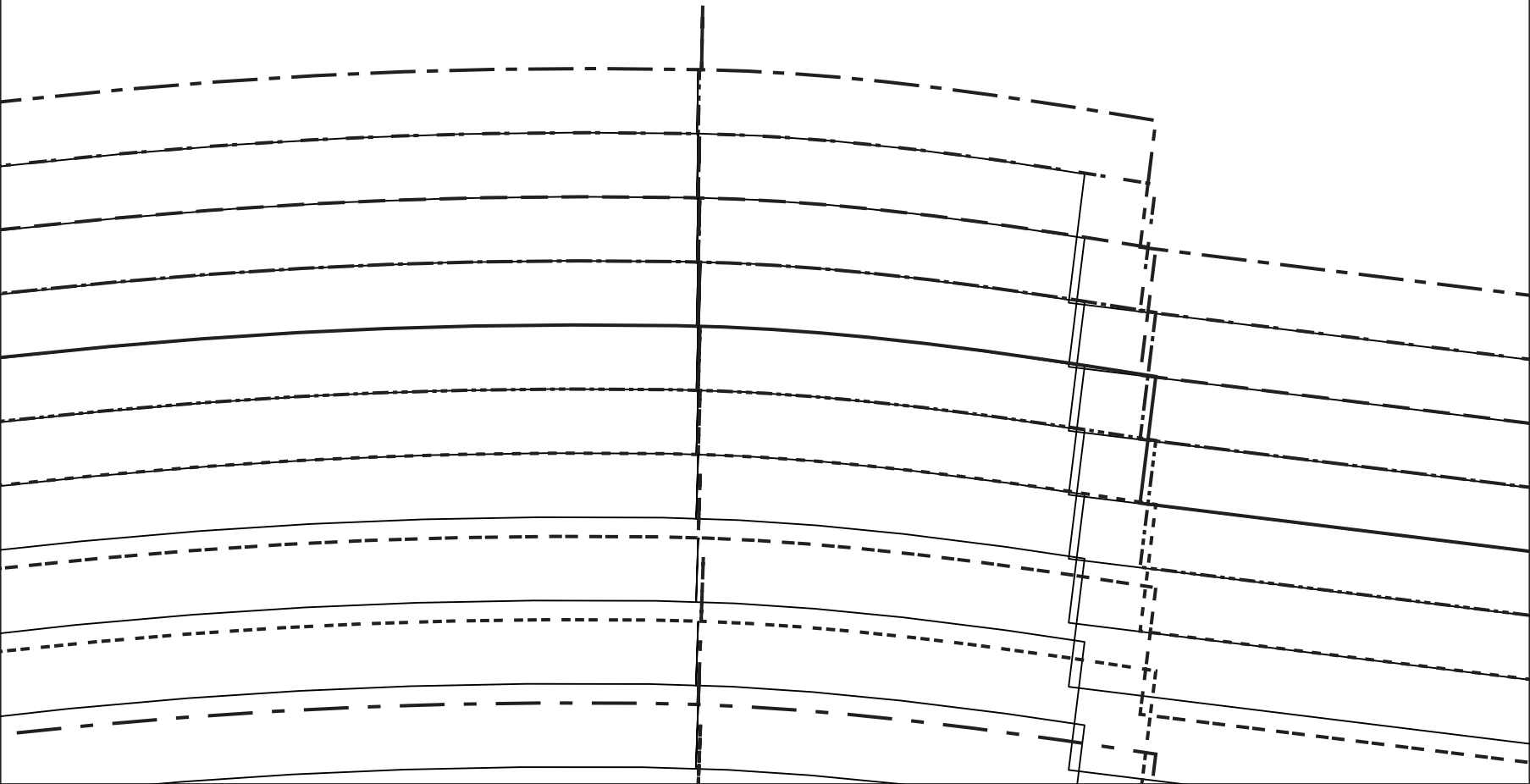

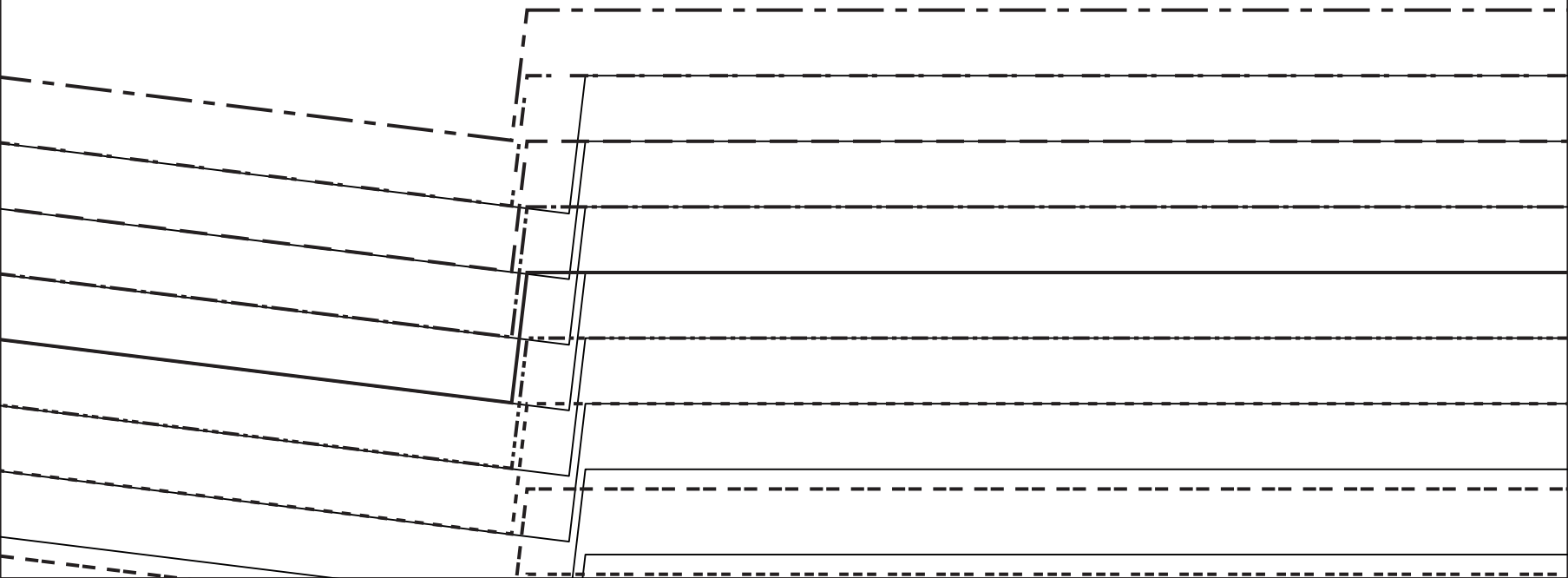

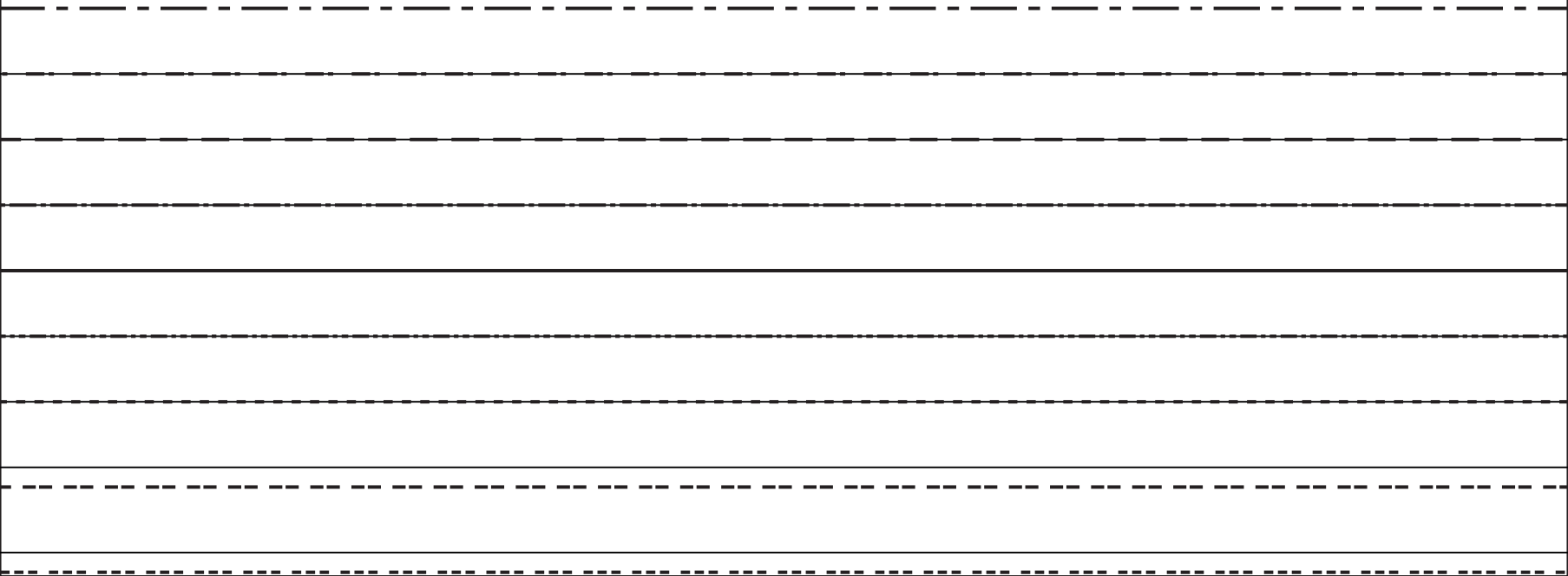

15

E/E'

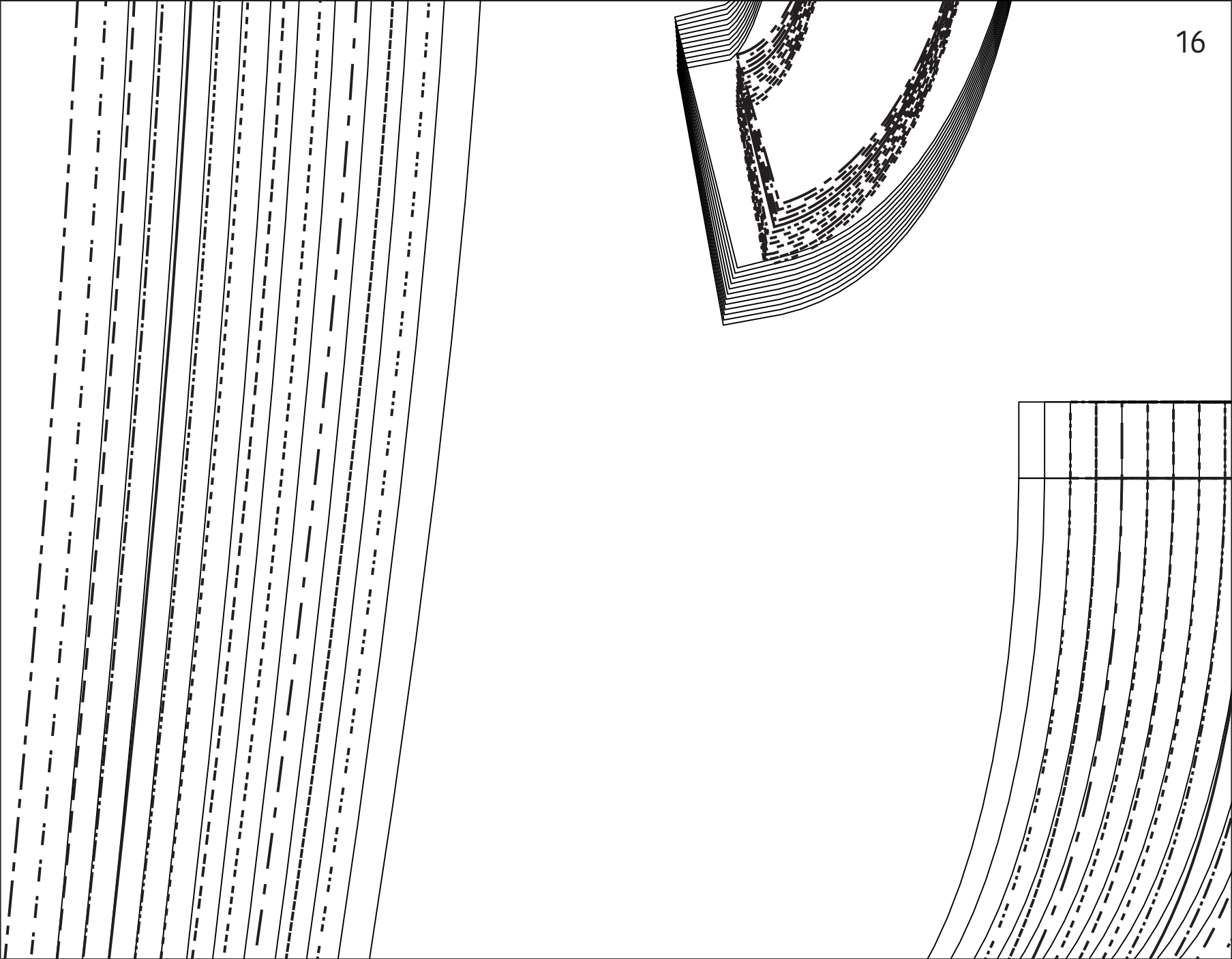

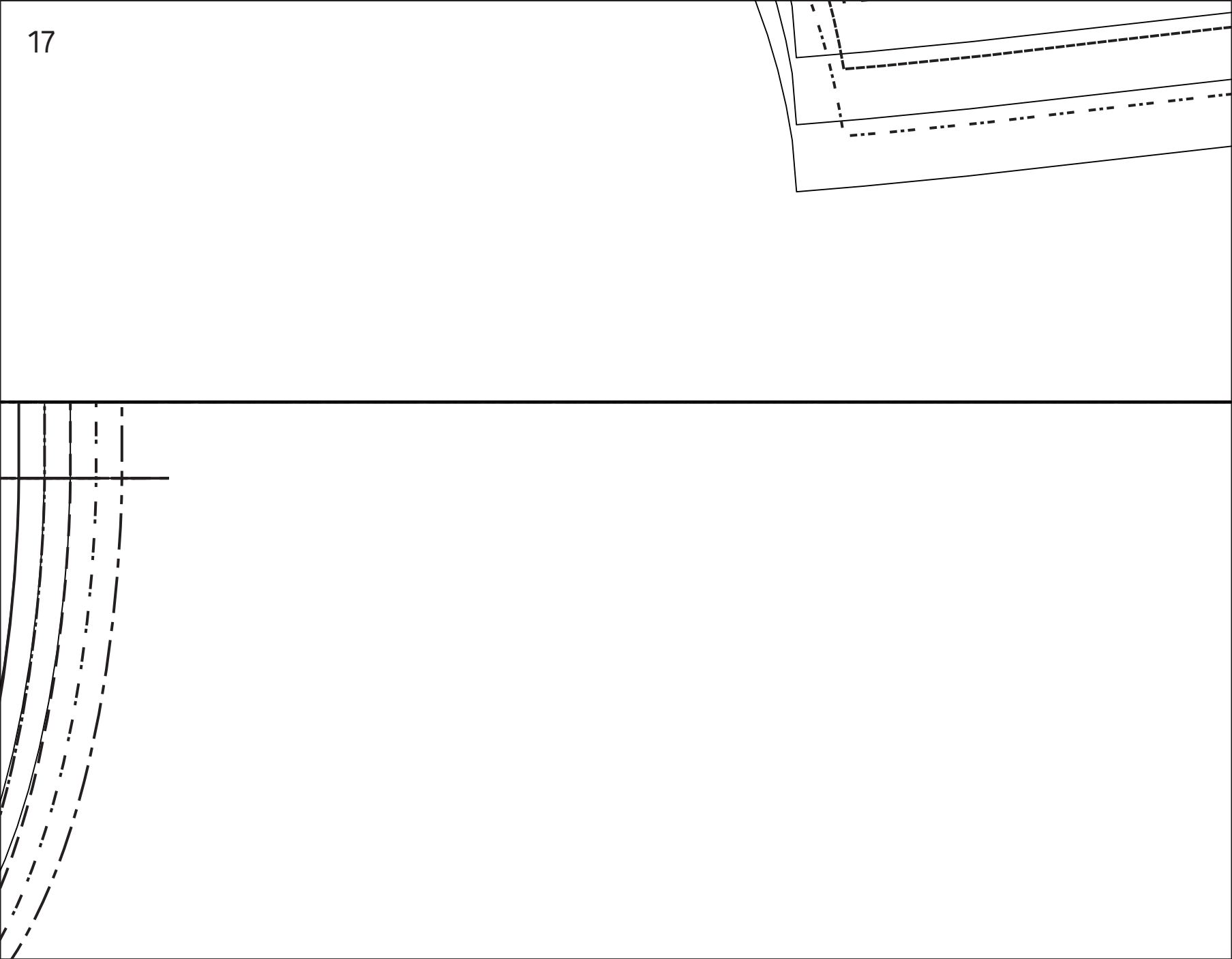

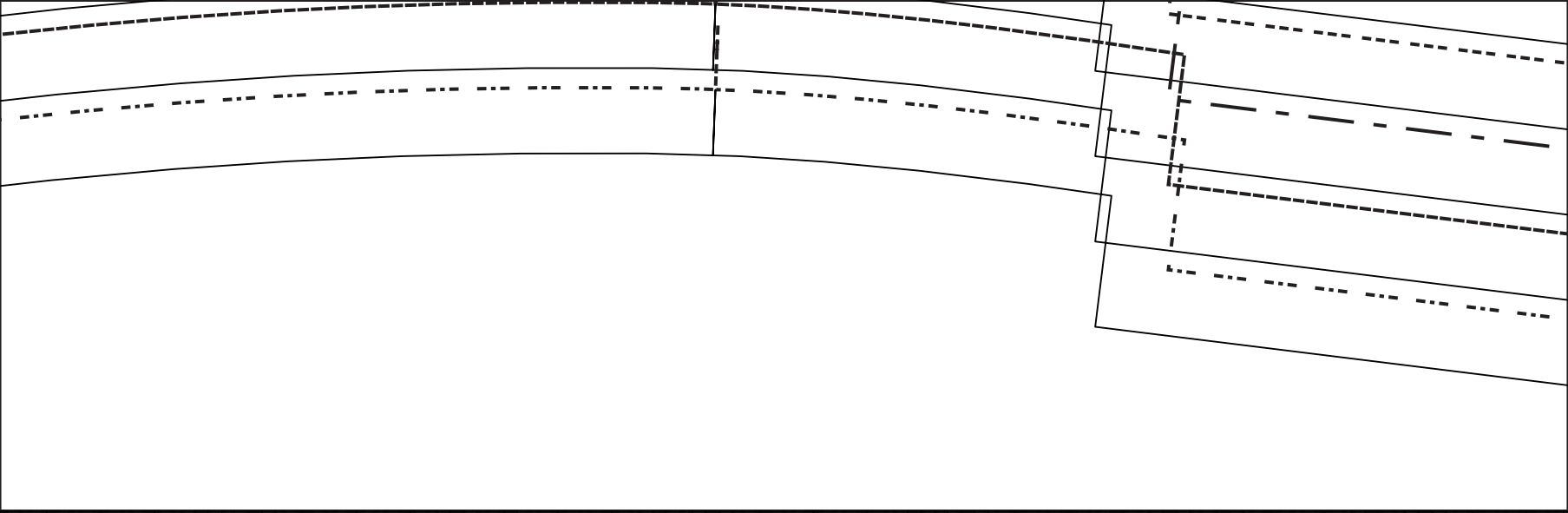

MR/MDS/CB/RM



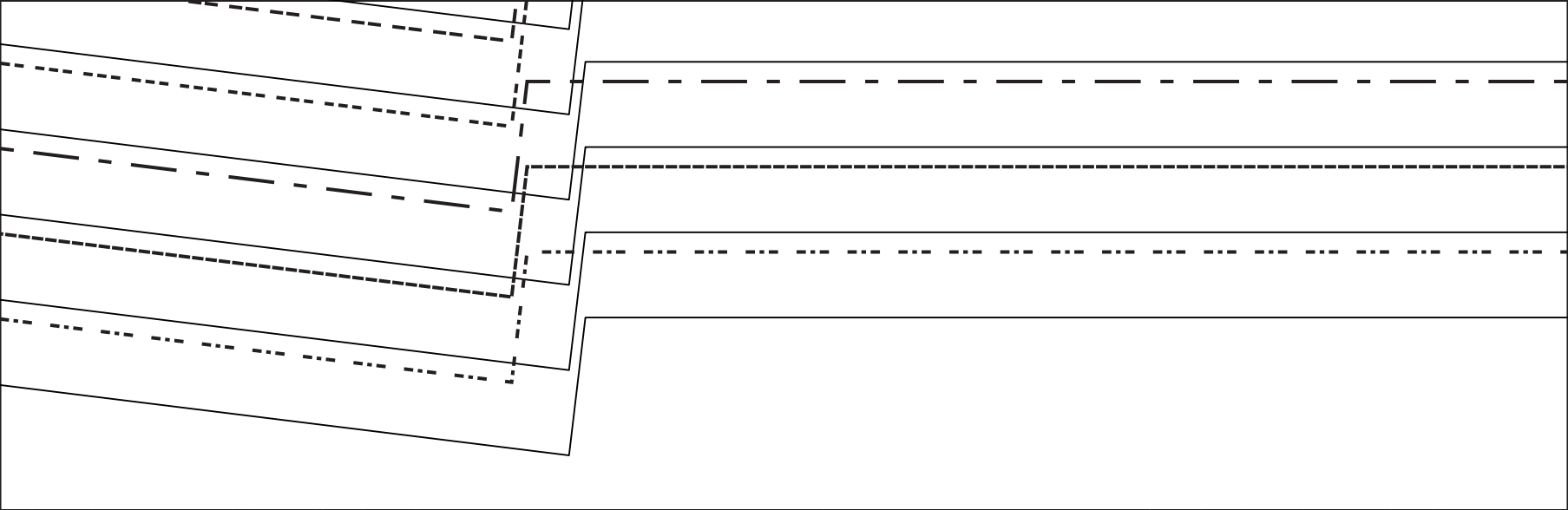

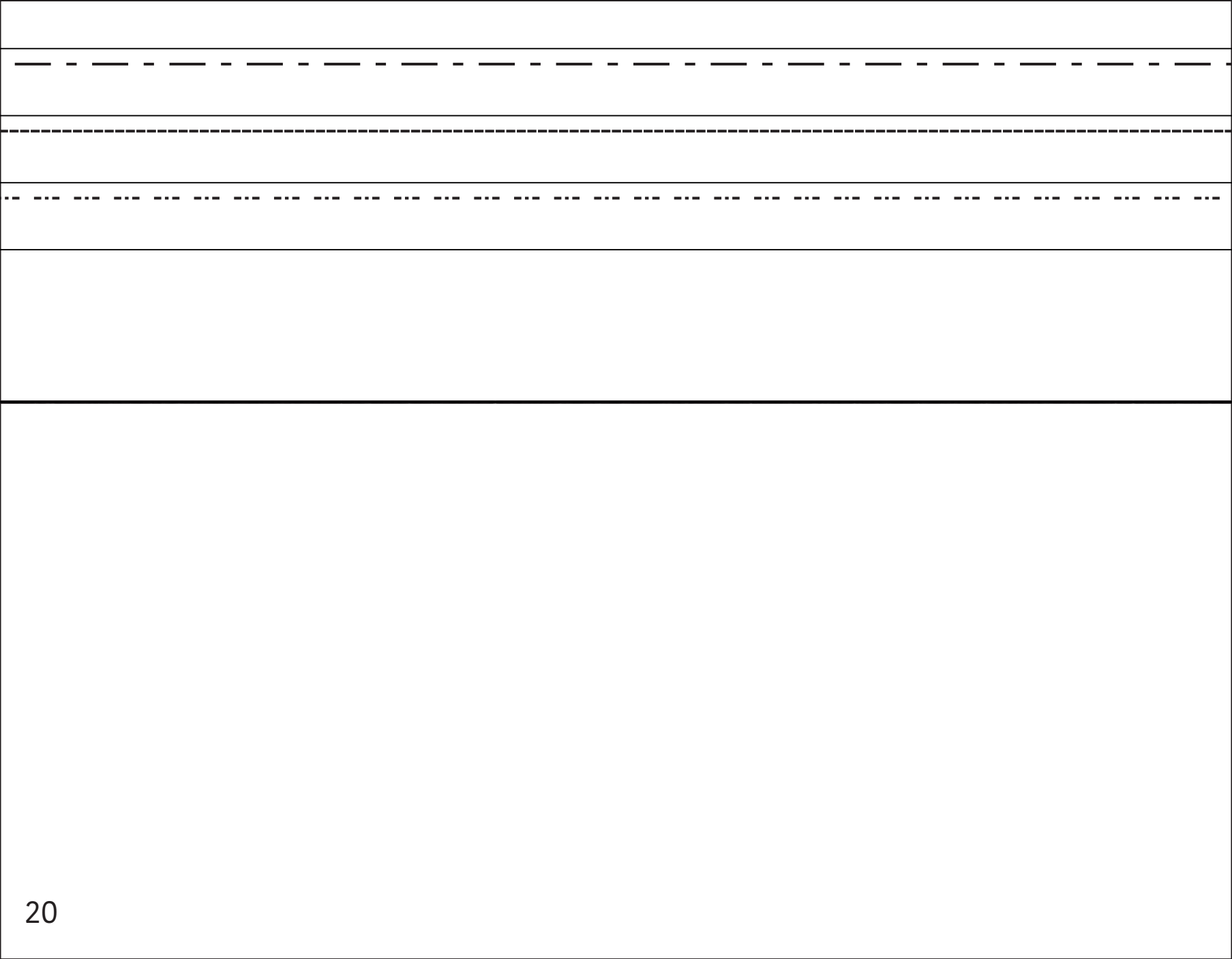

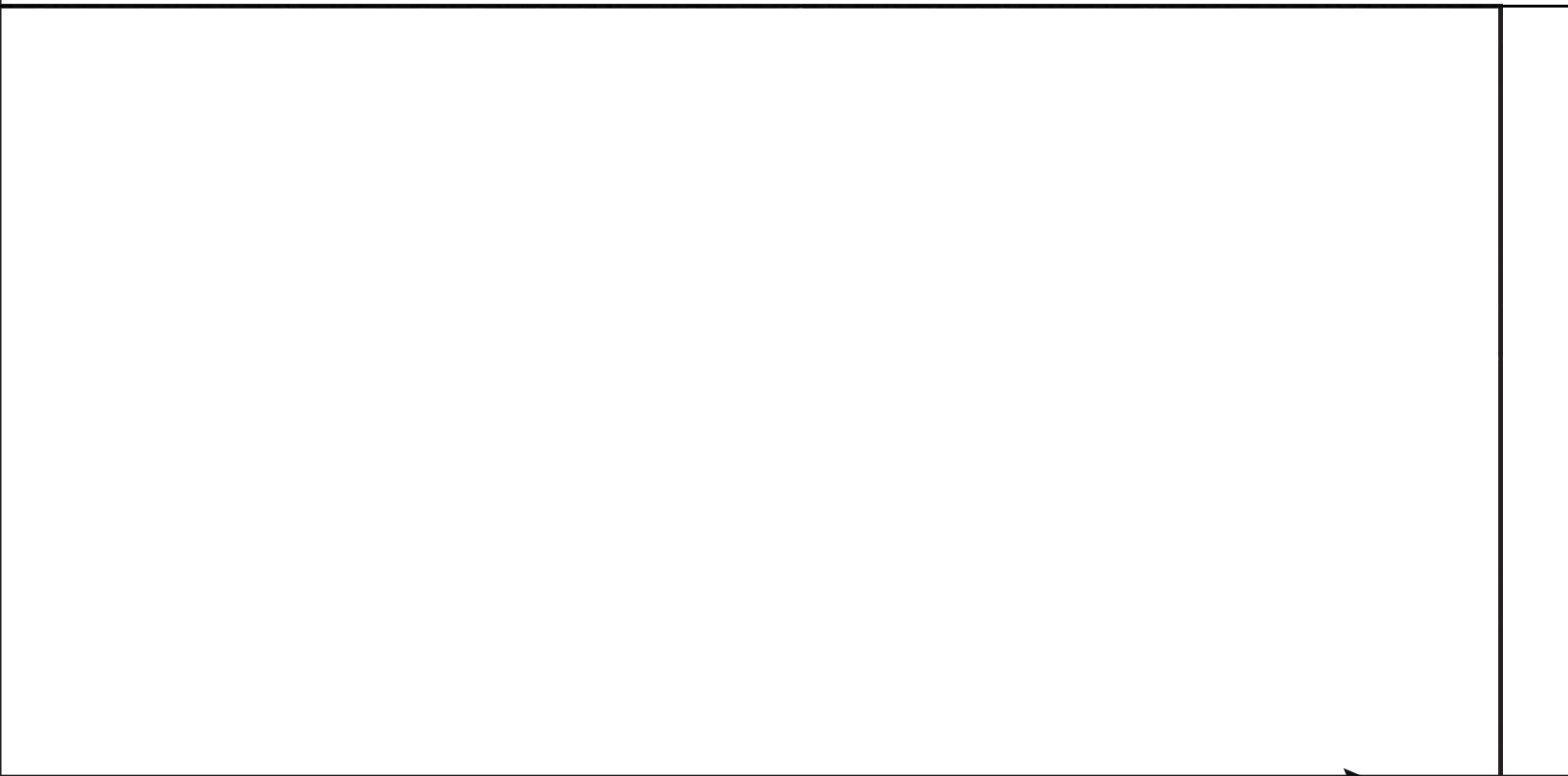
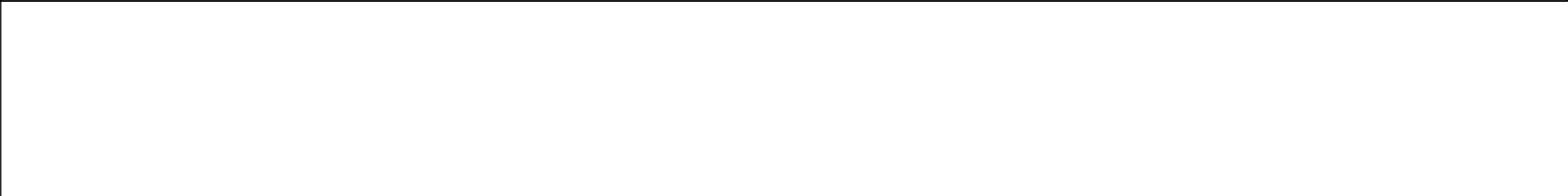

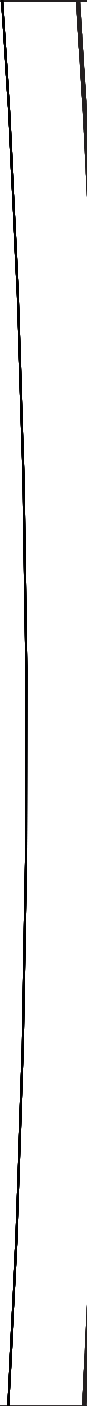

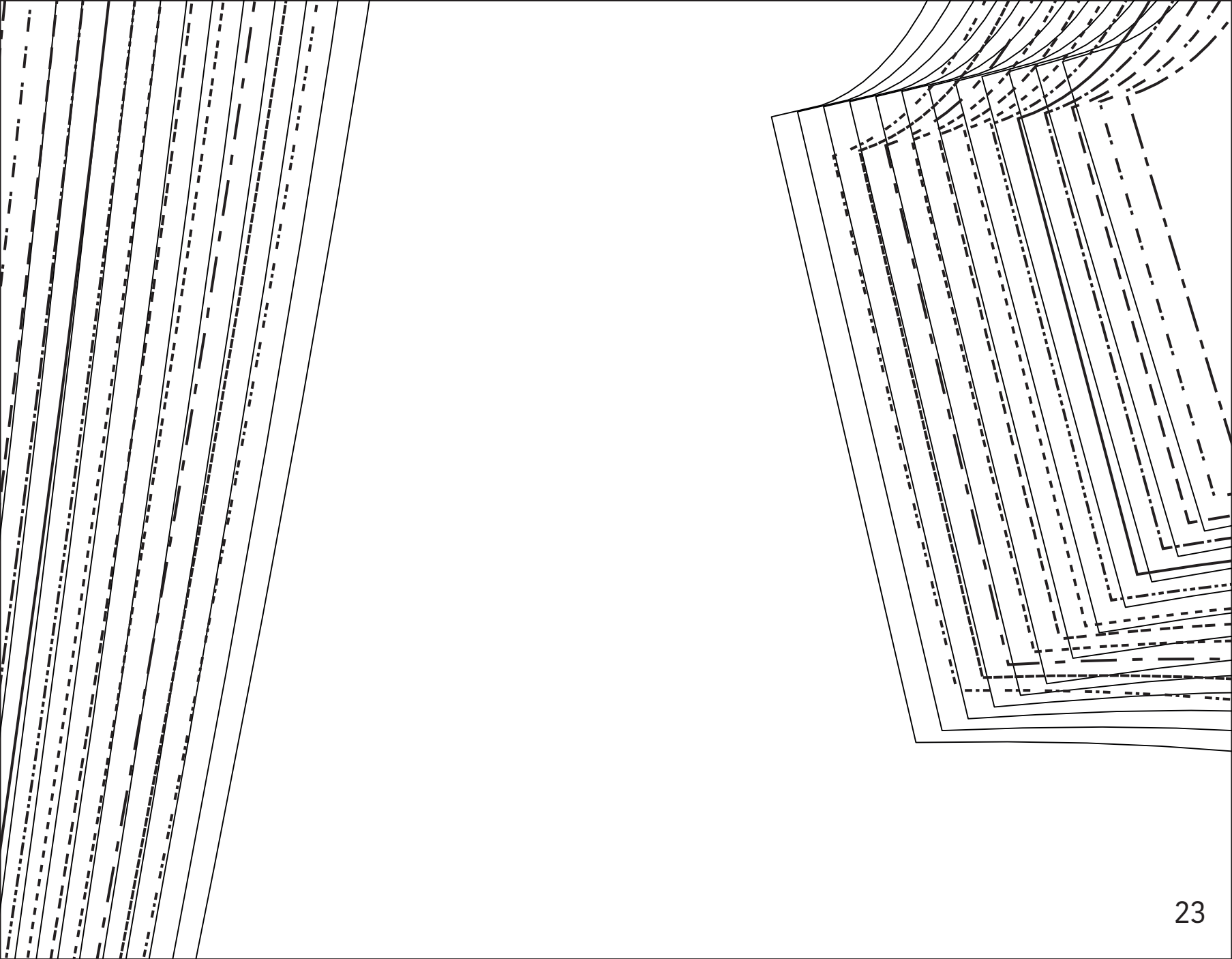

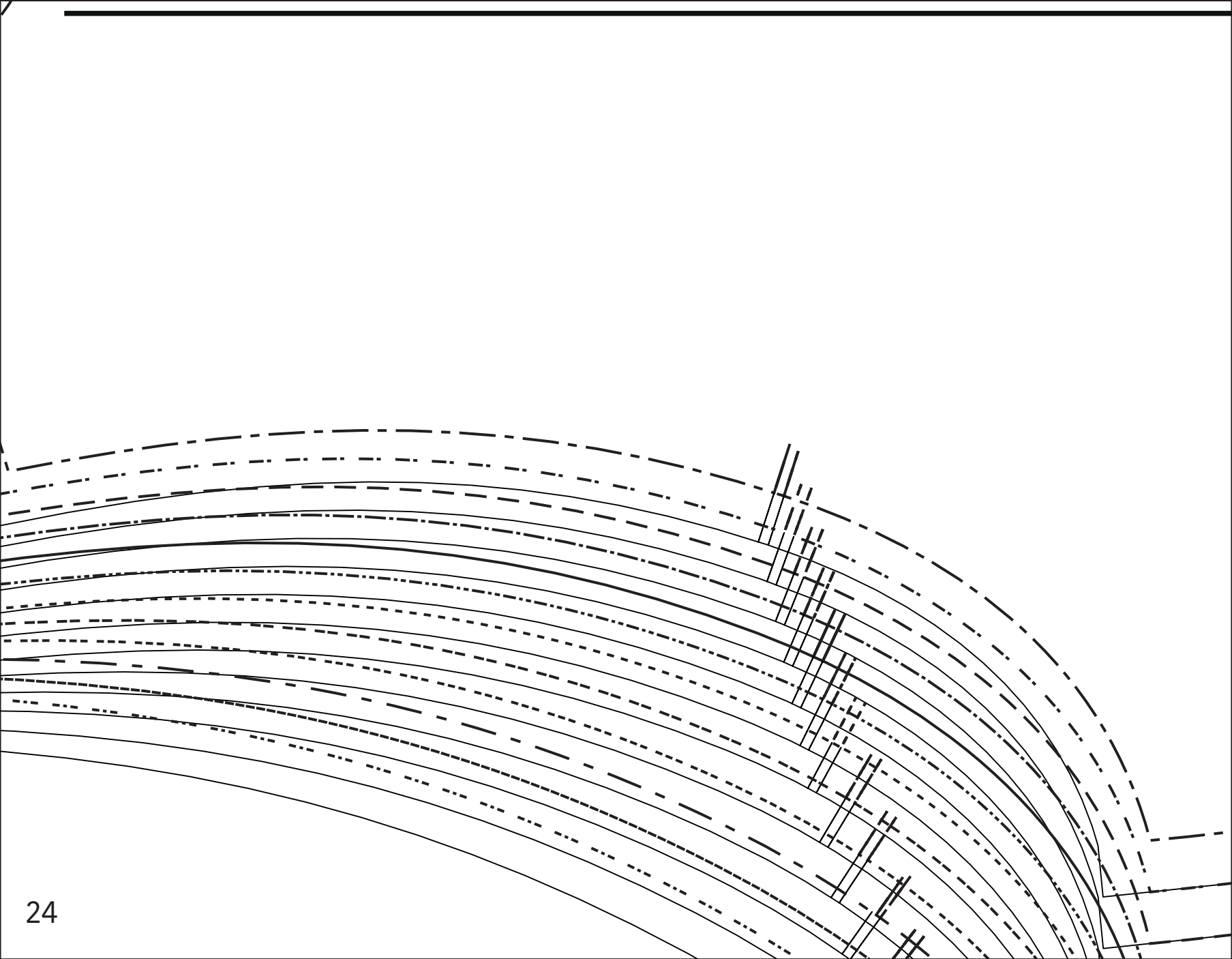

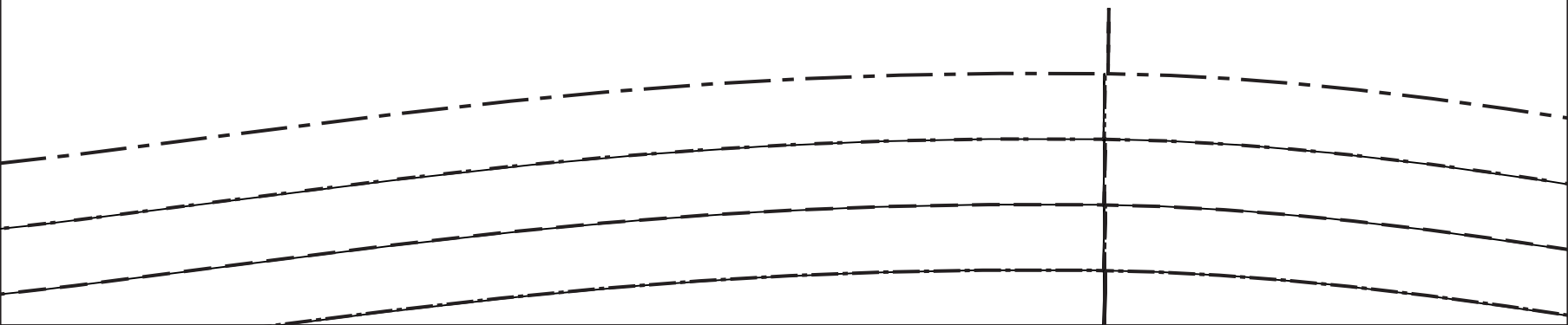

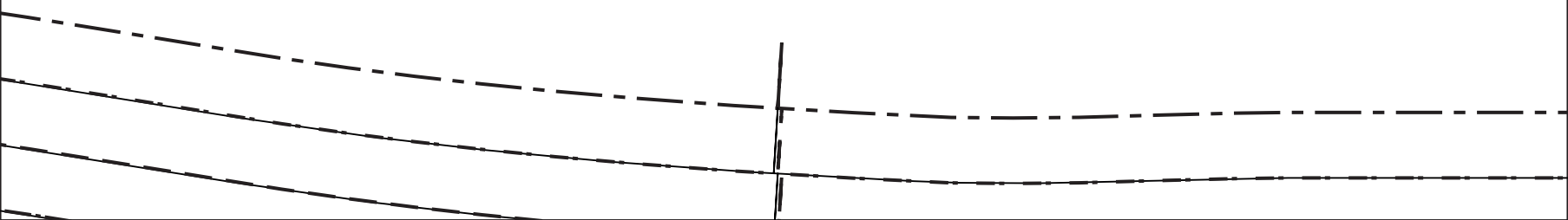





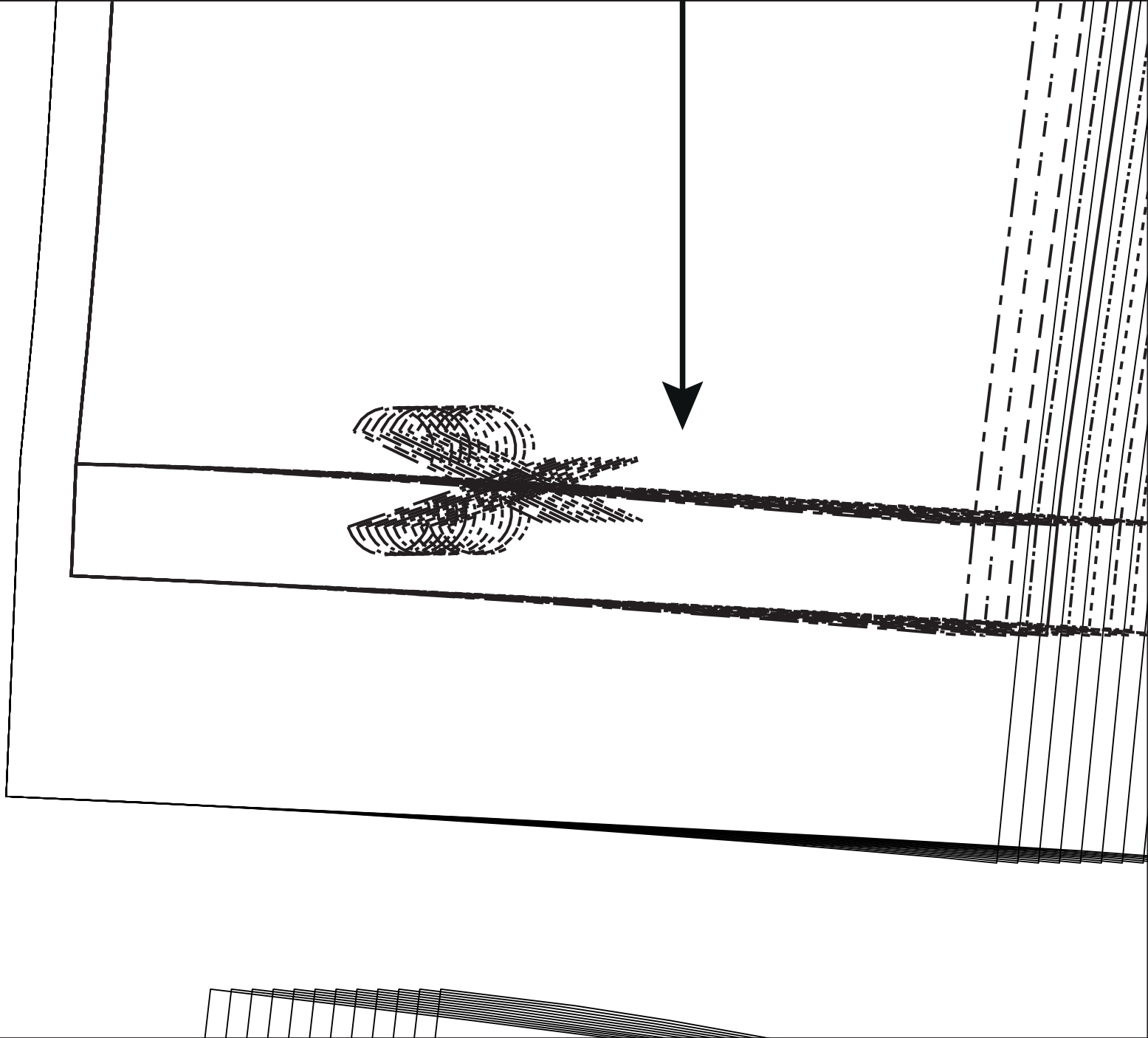

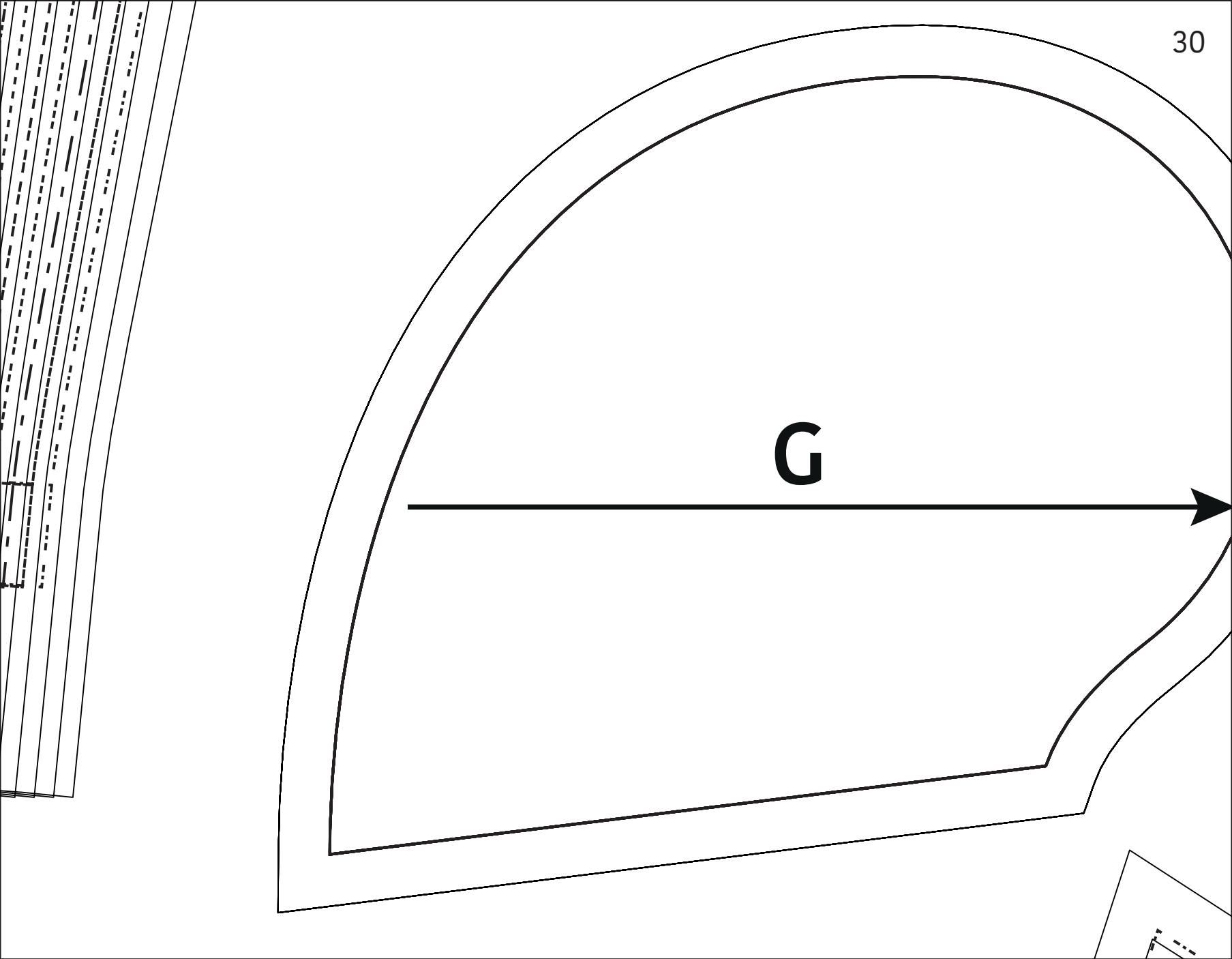

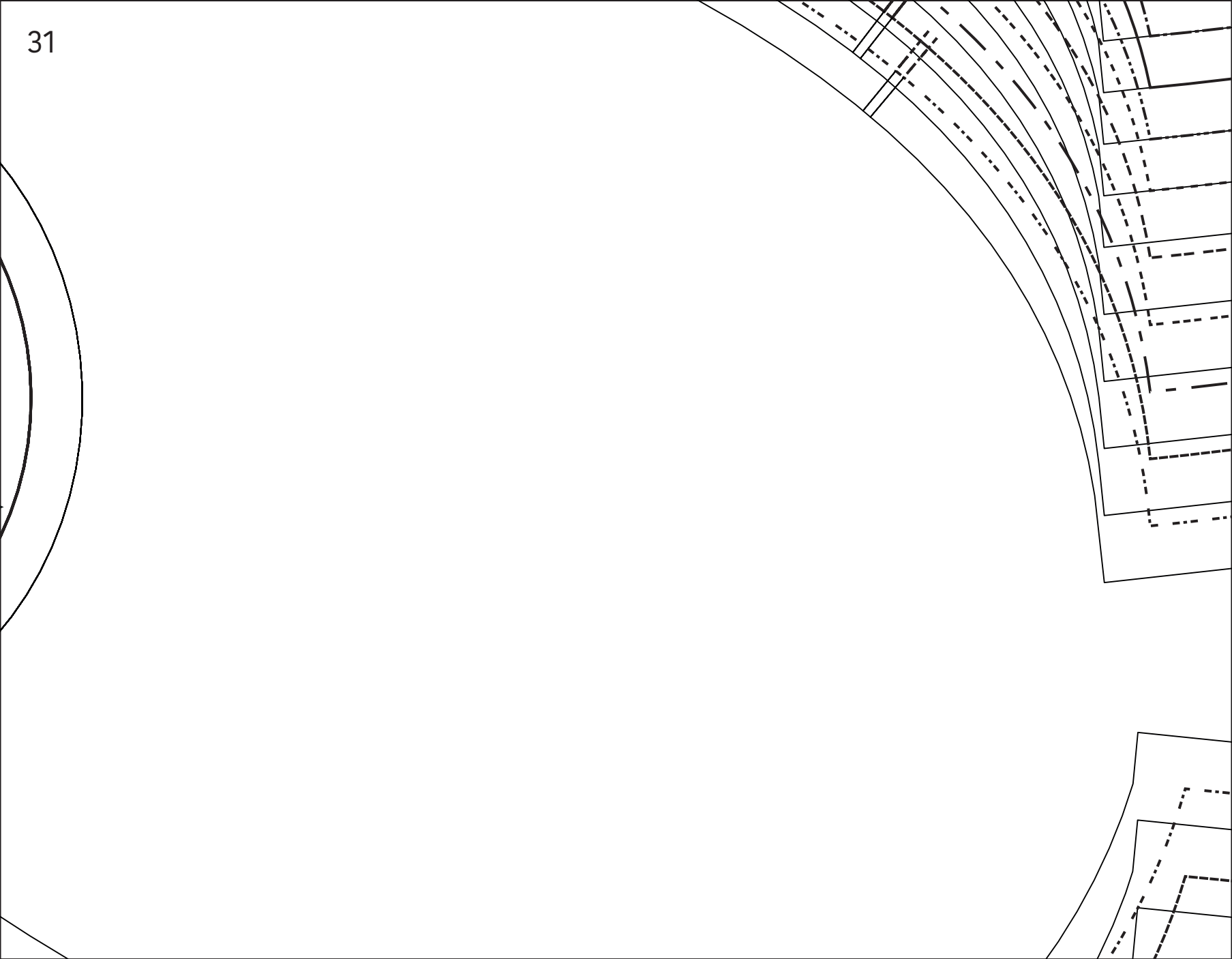

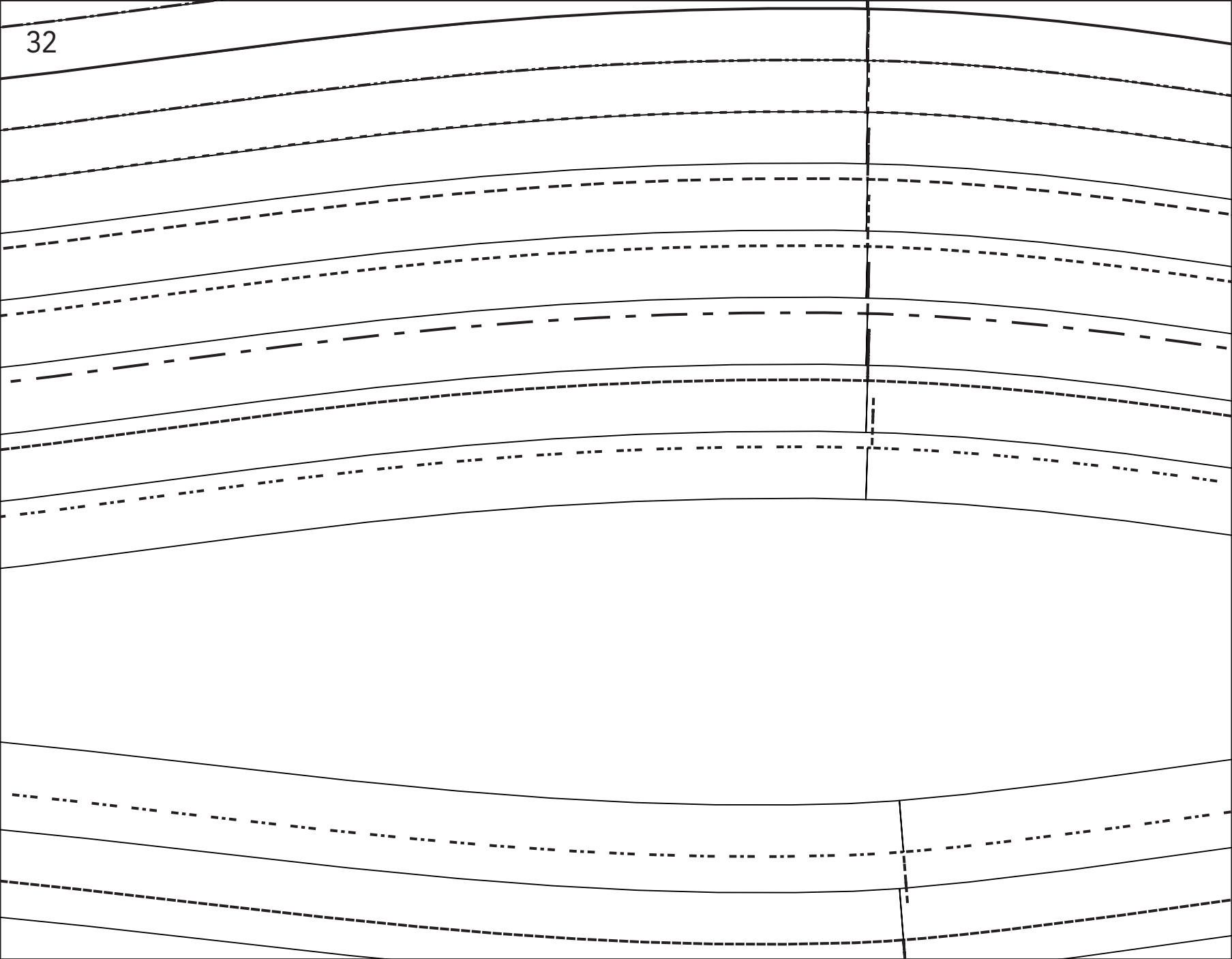

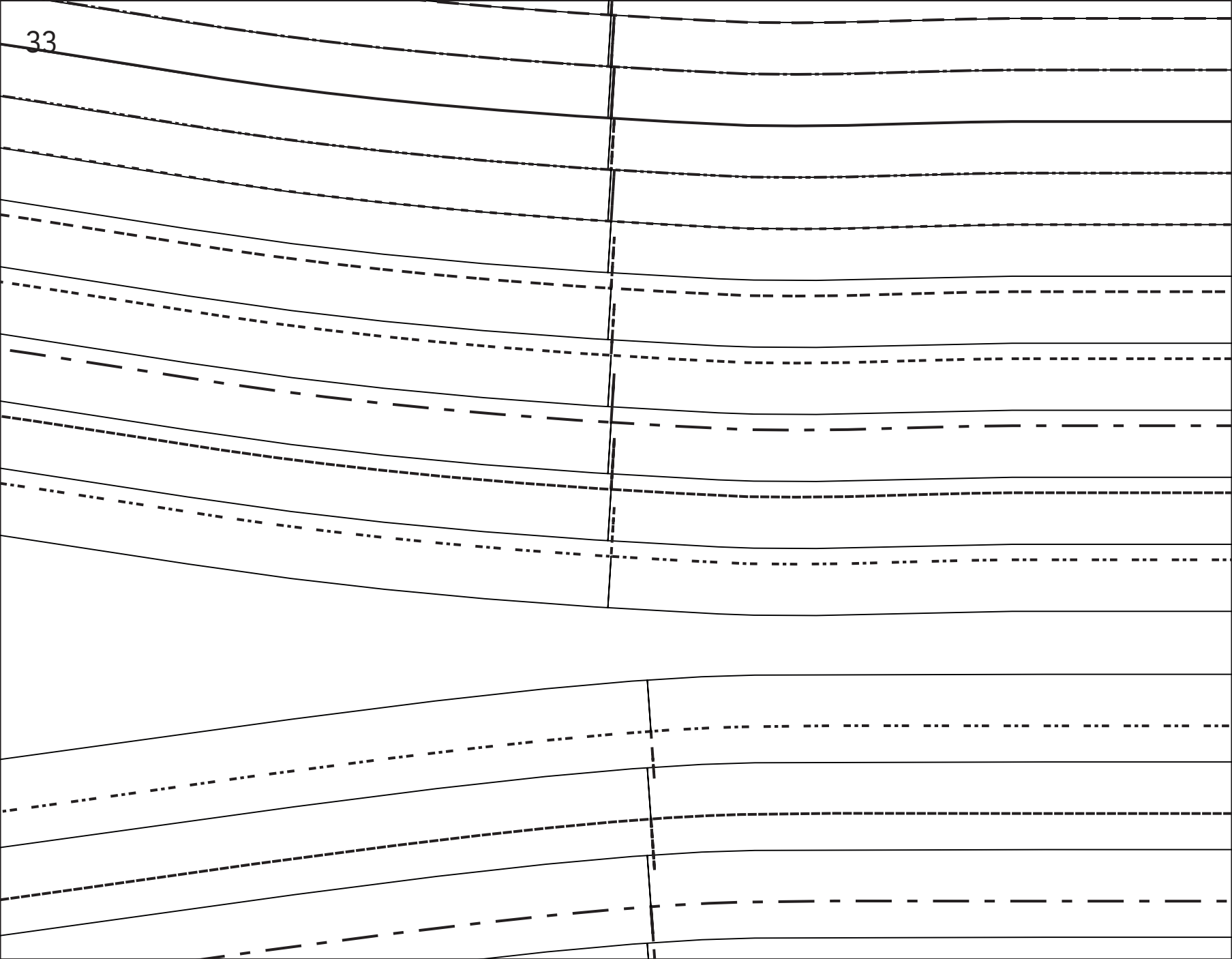

A series of horizontal lines for writing, consisting of solid top and bottom lines and a dashed middle line, repeated across the page.

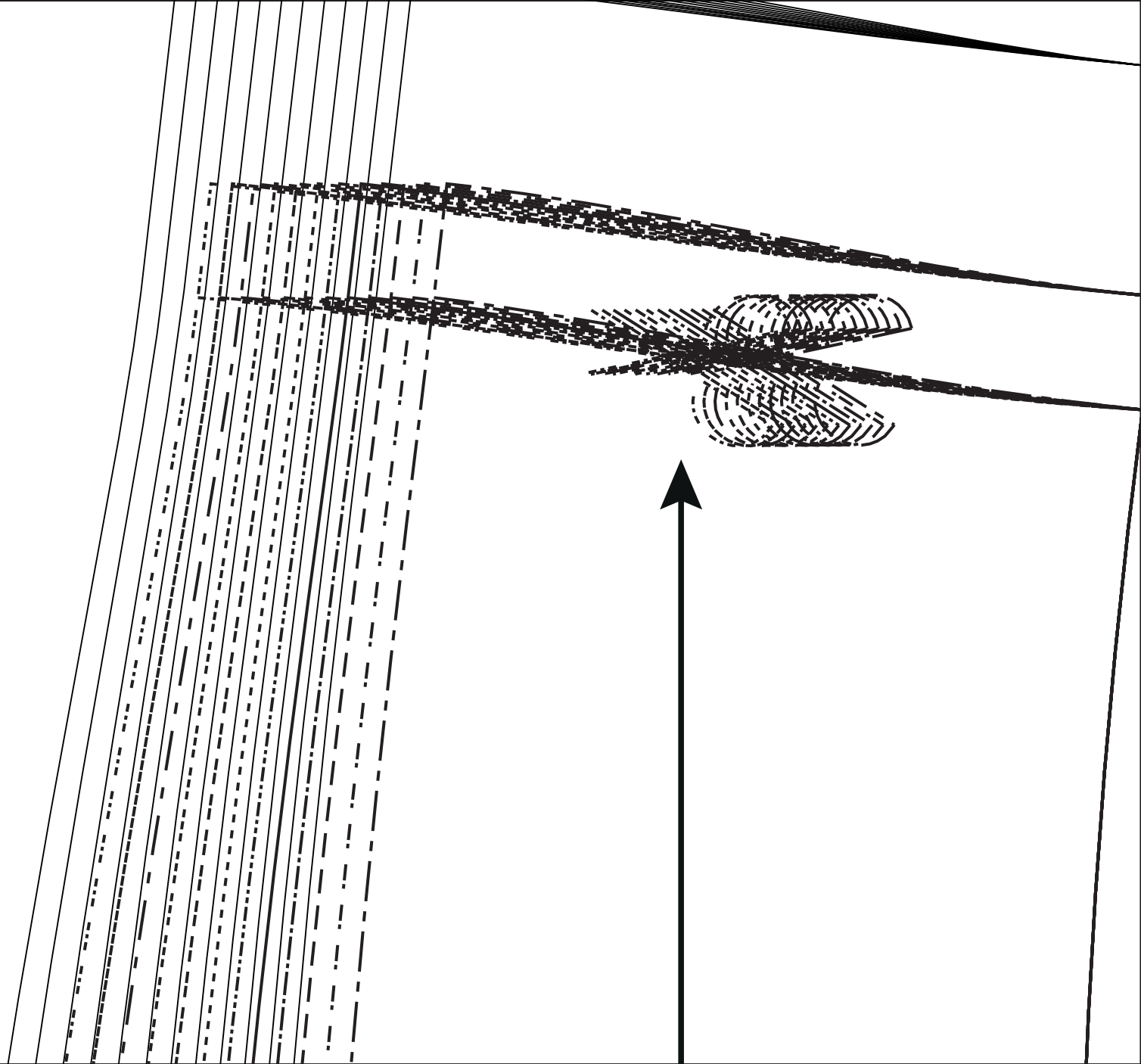

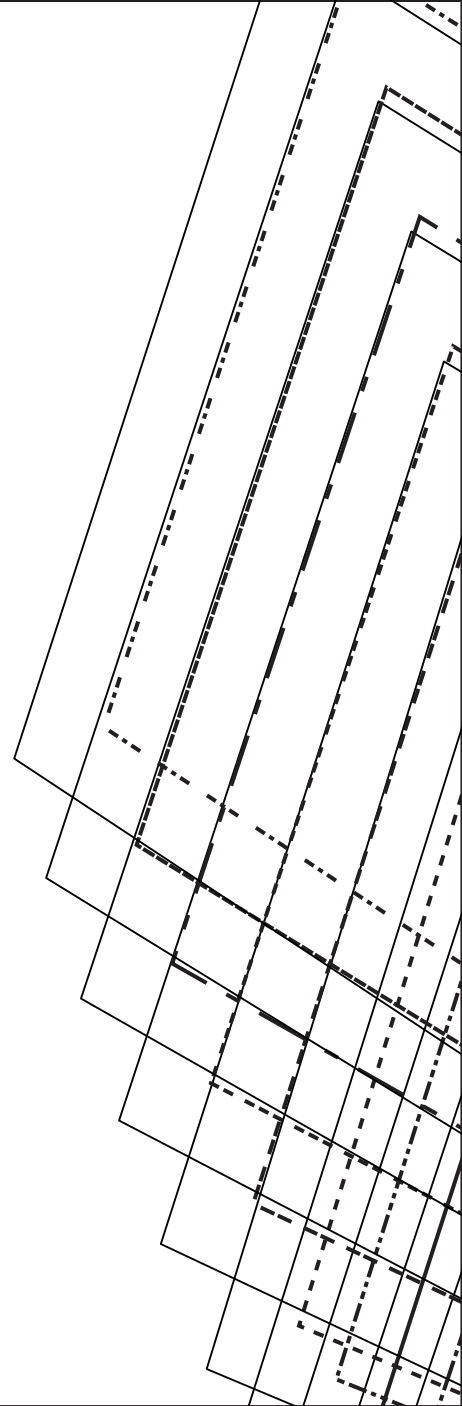
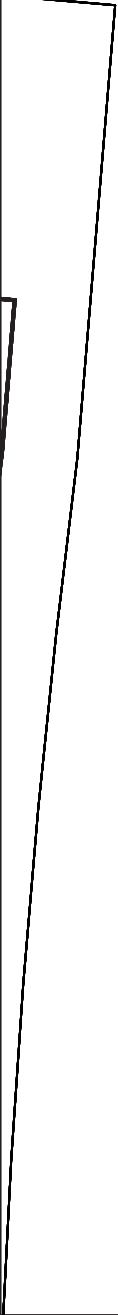

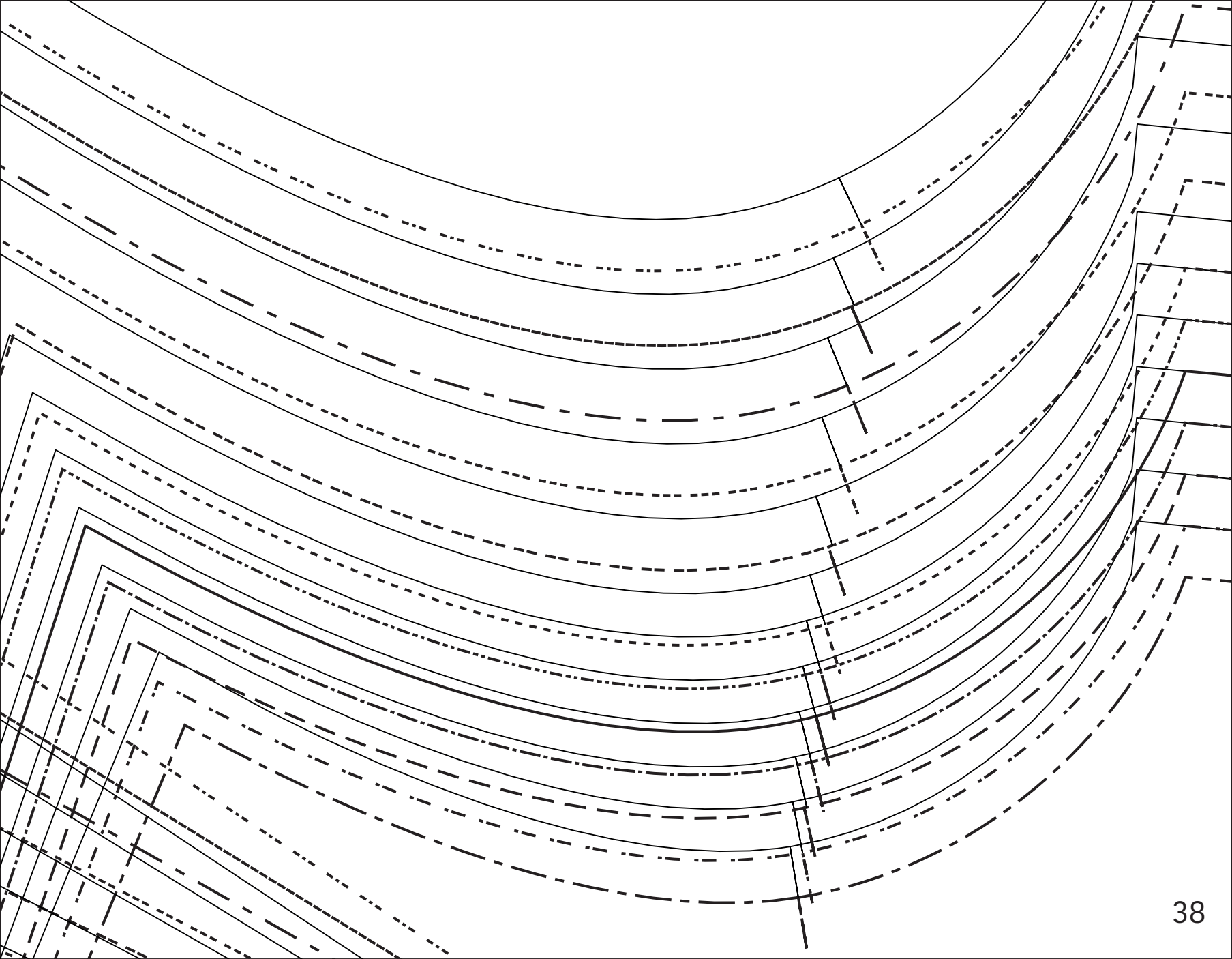

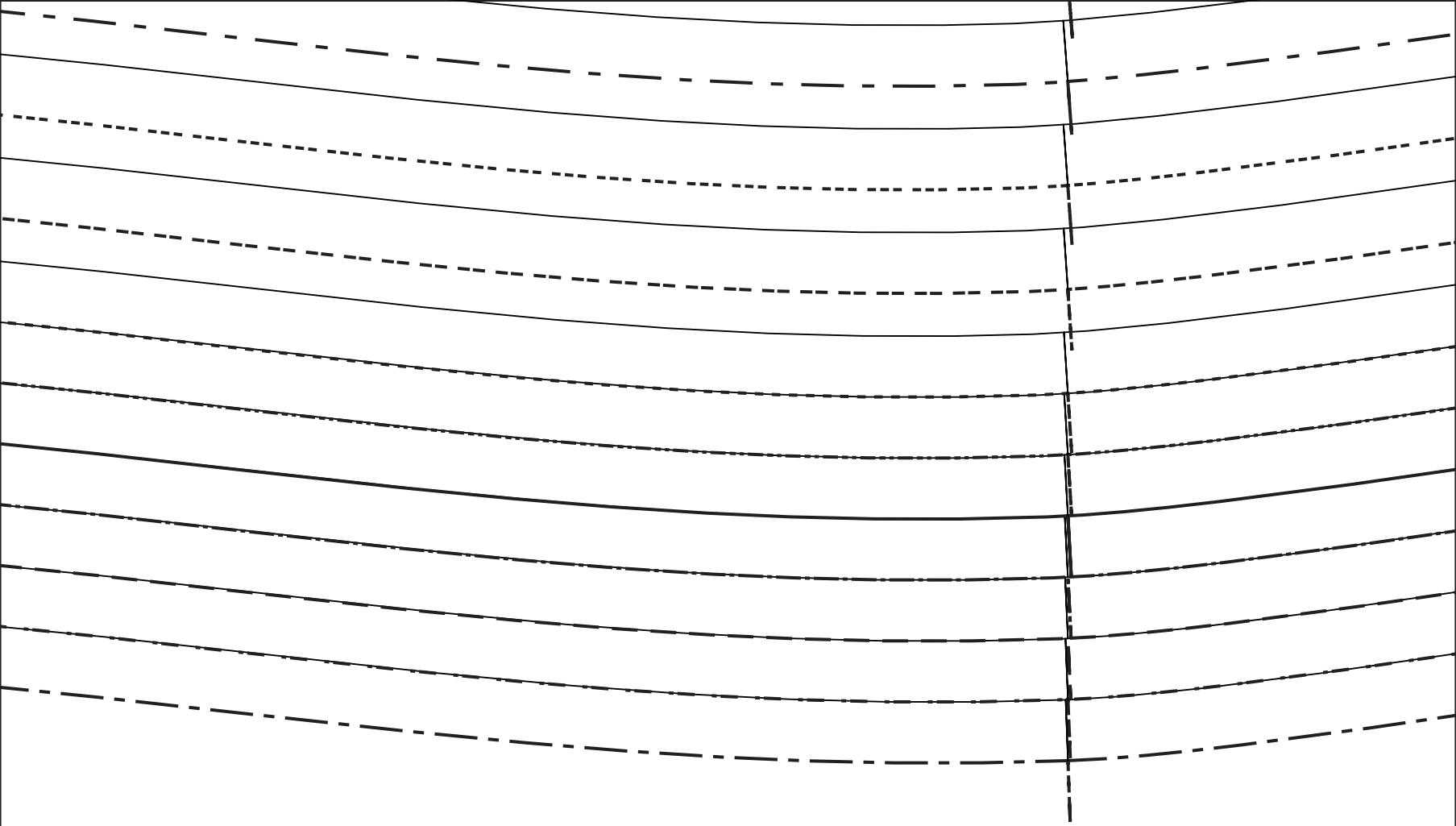

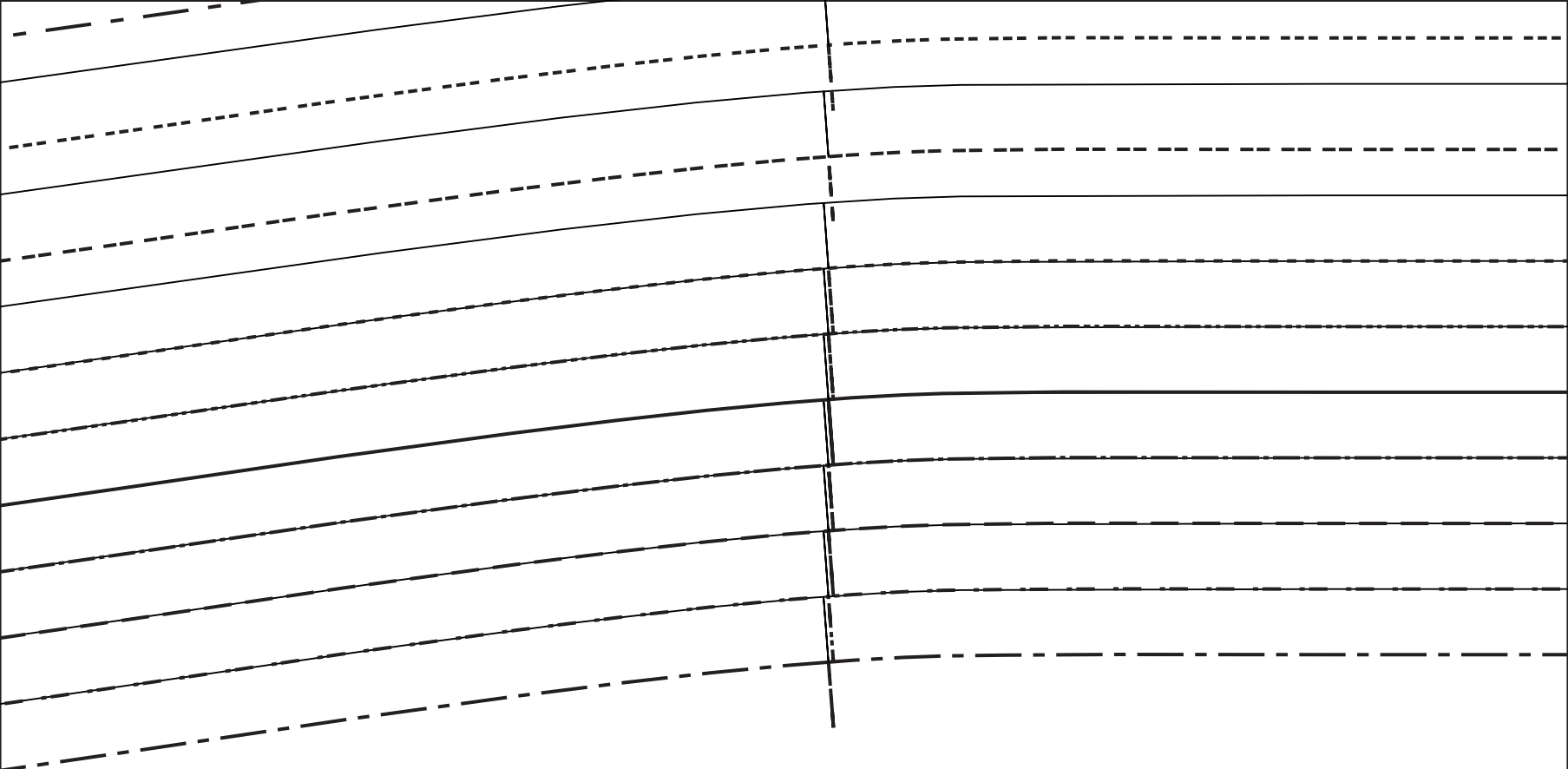

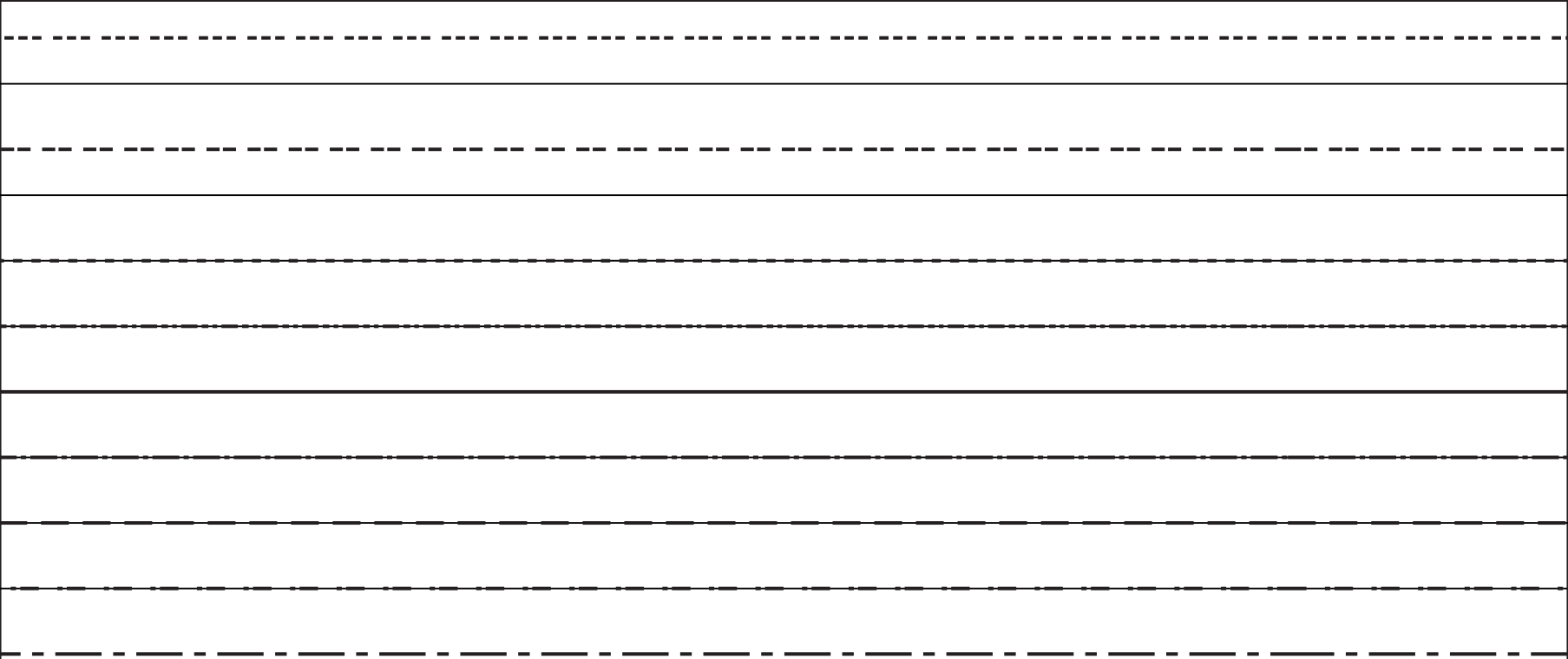

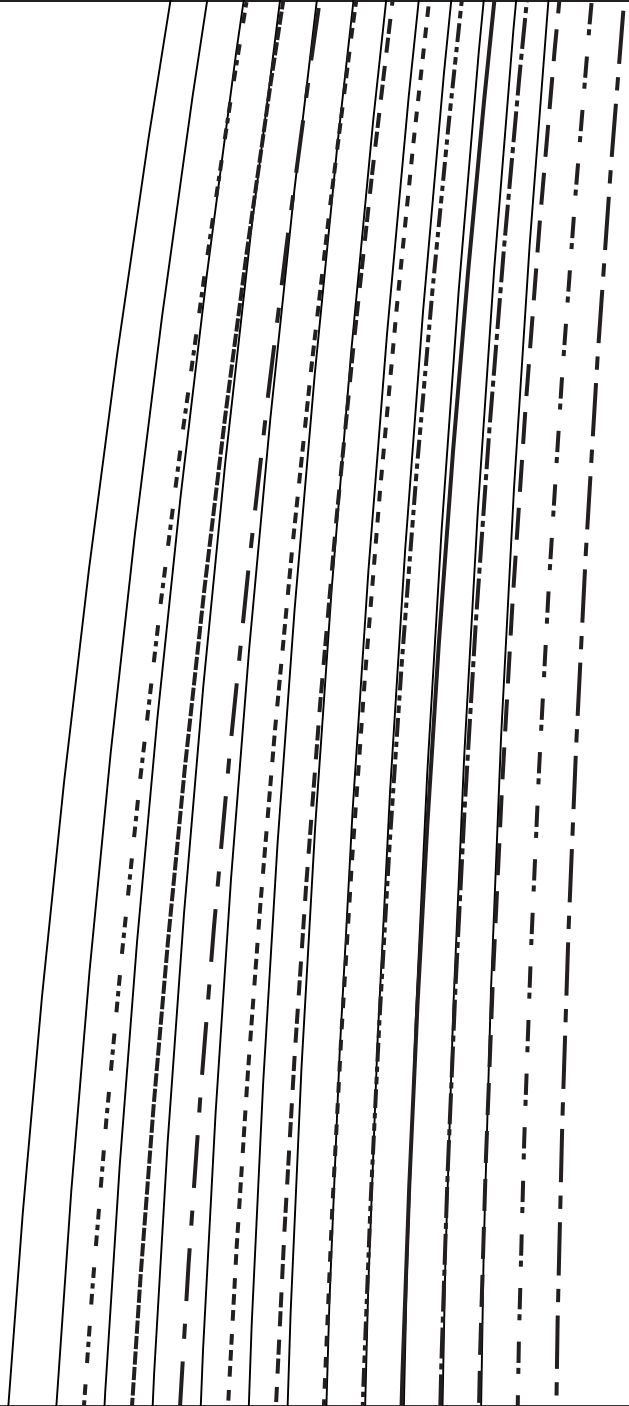

F/F'

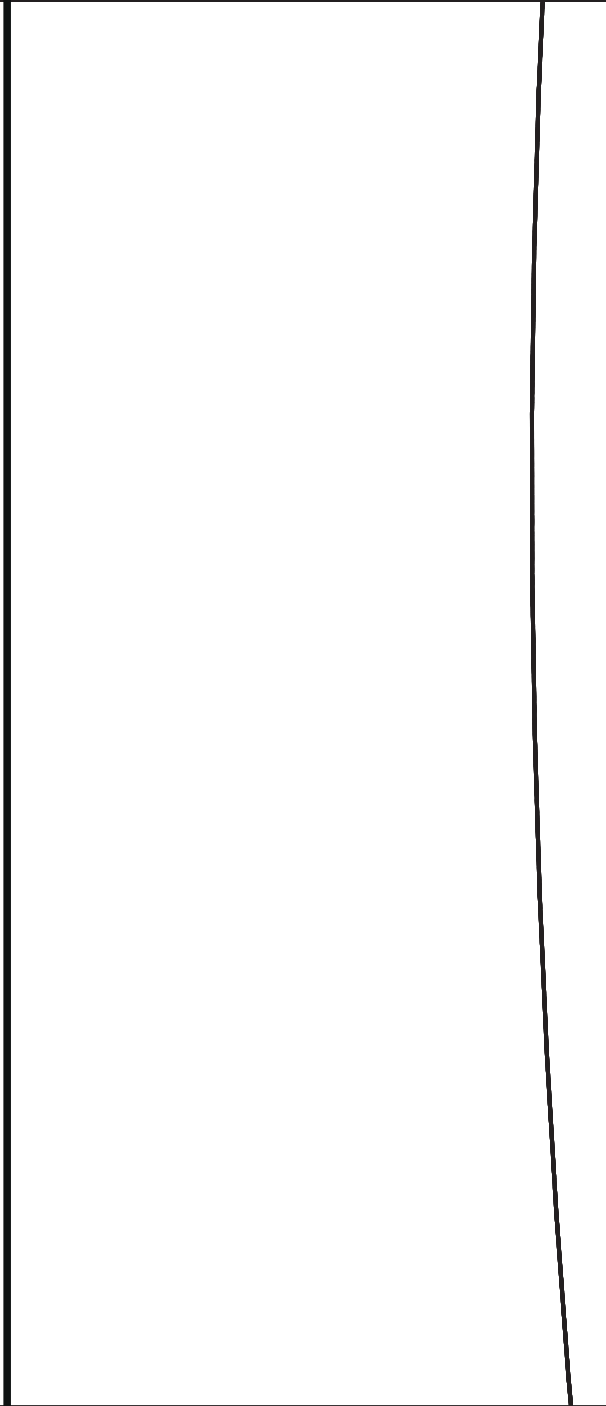

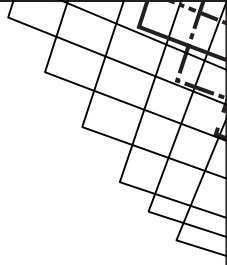

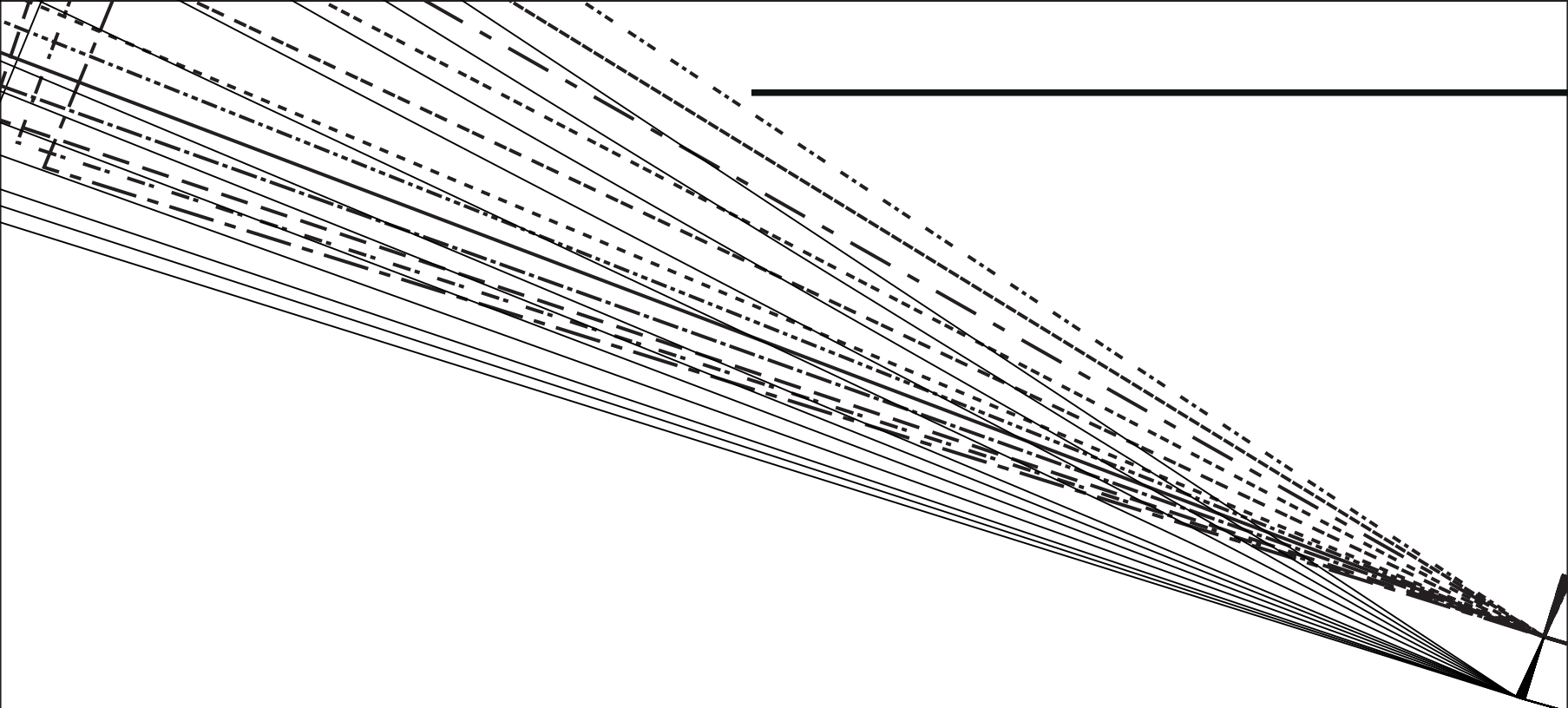

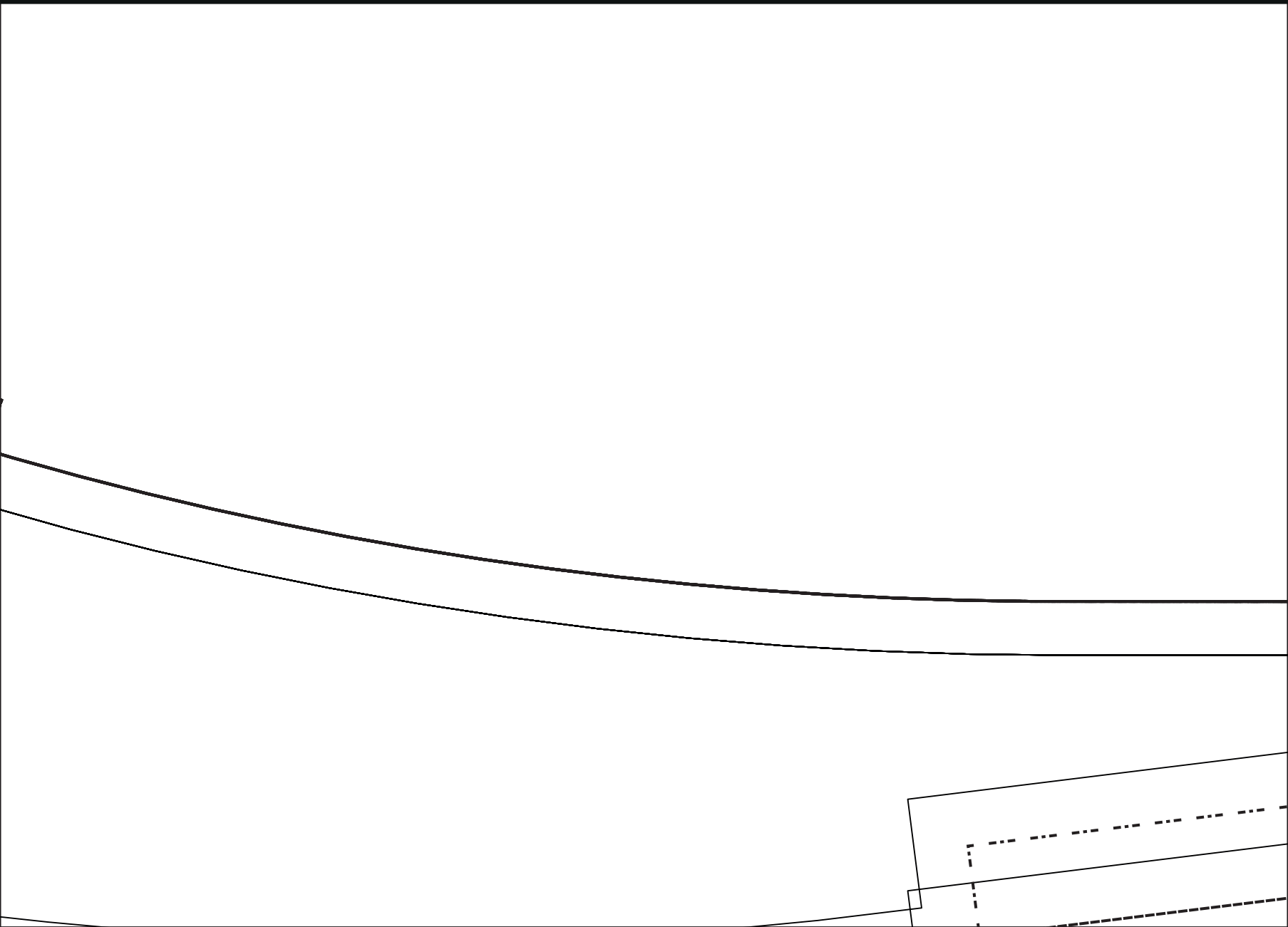

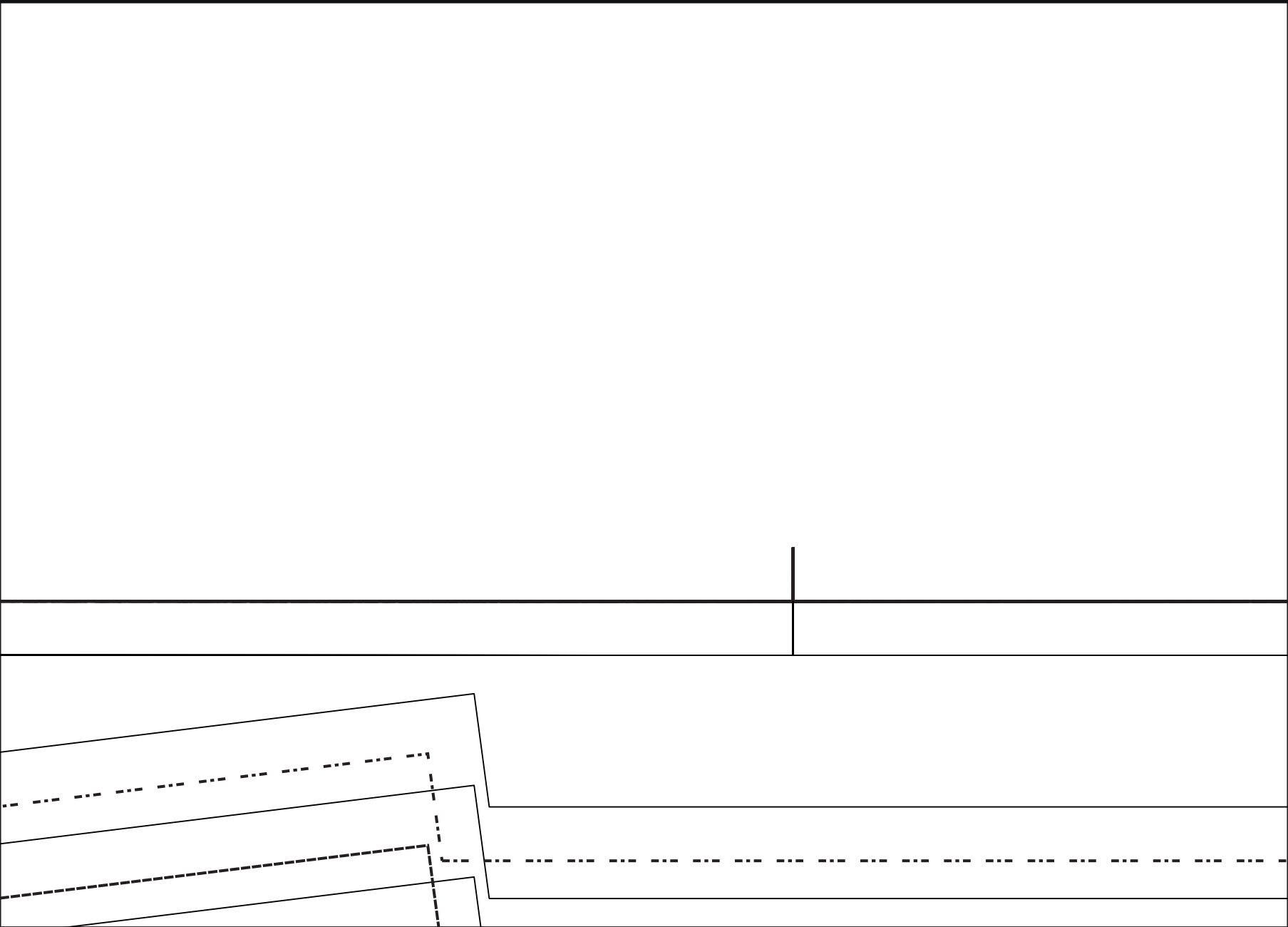

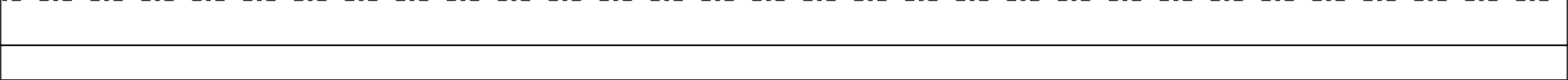
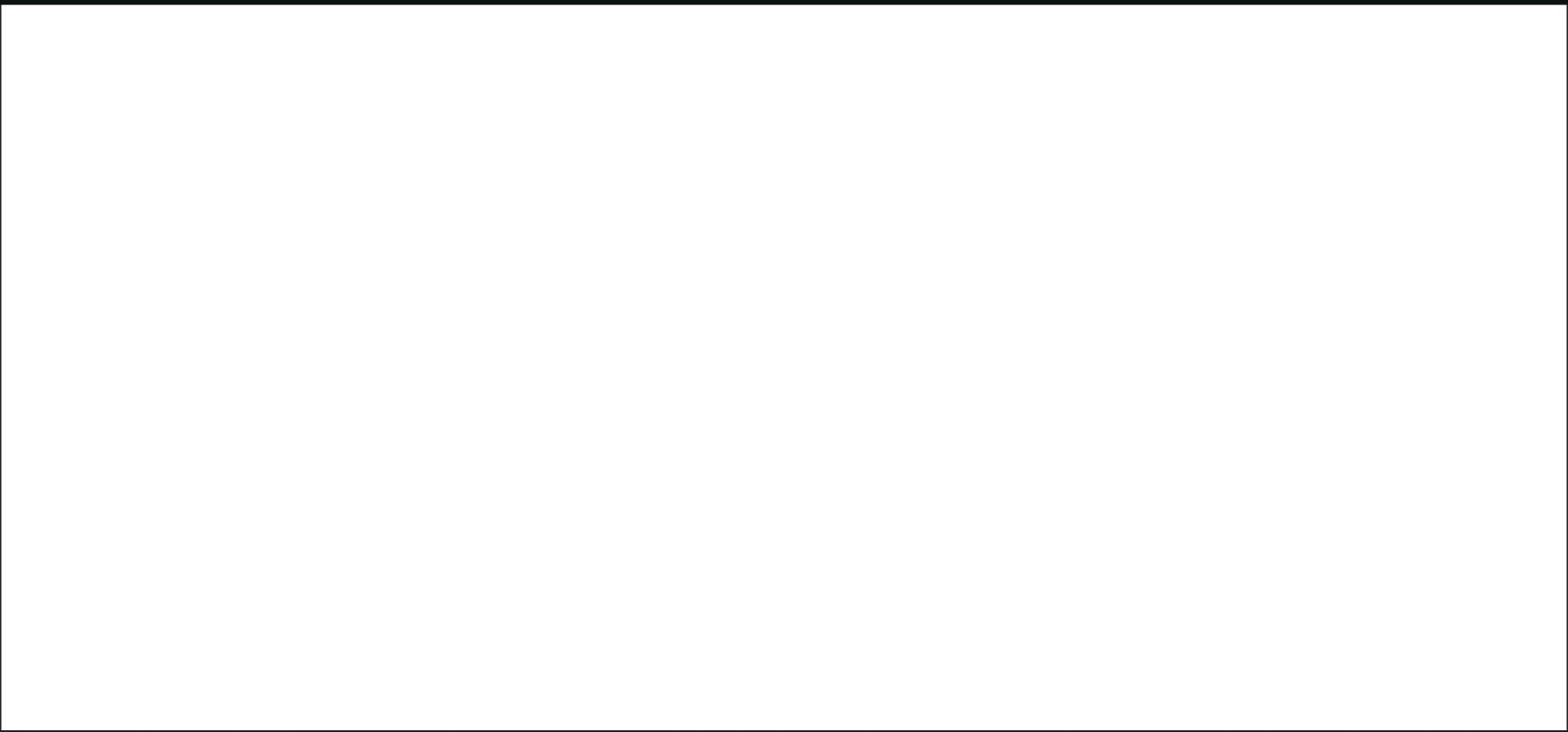



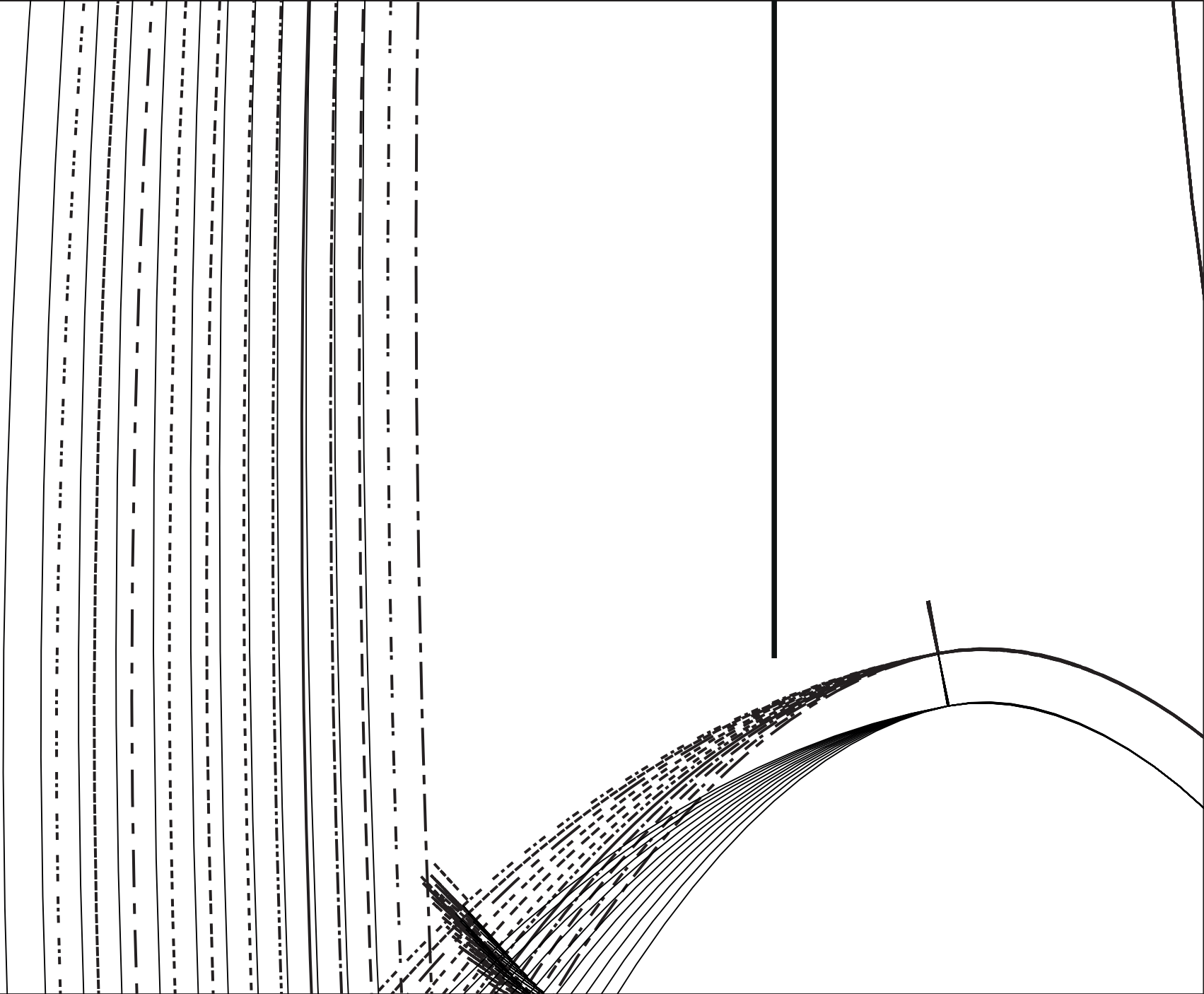

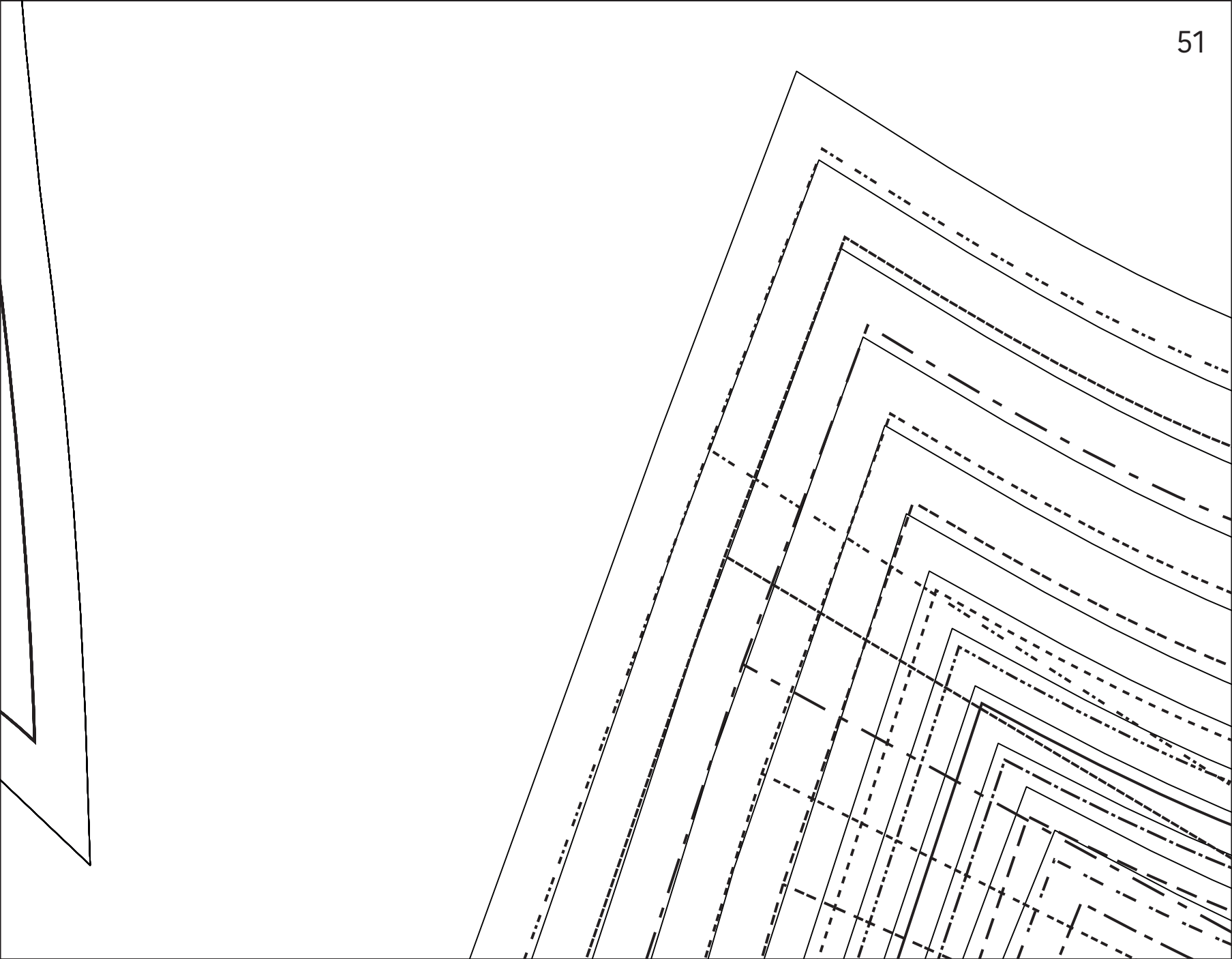

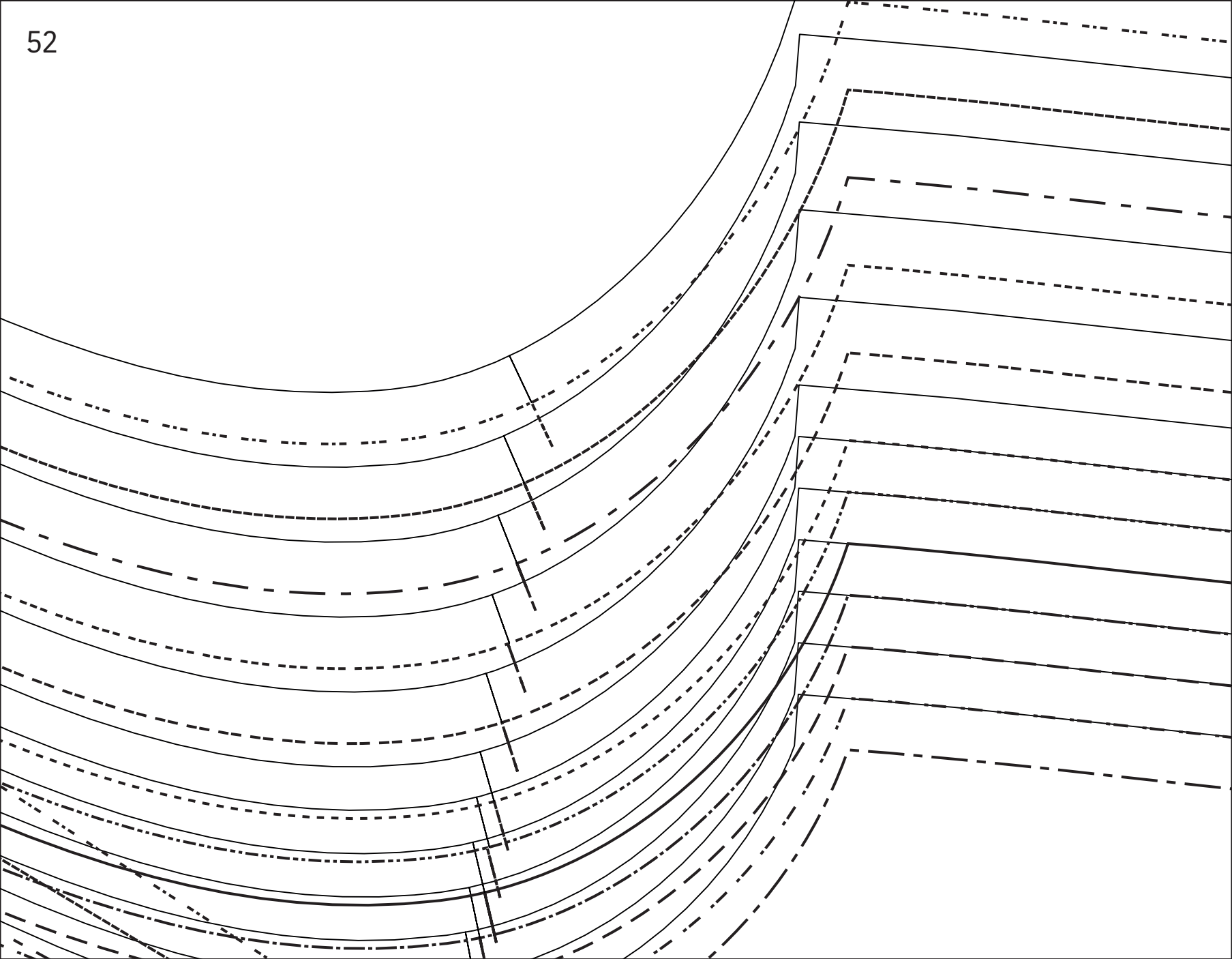

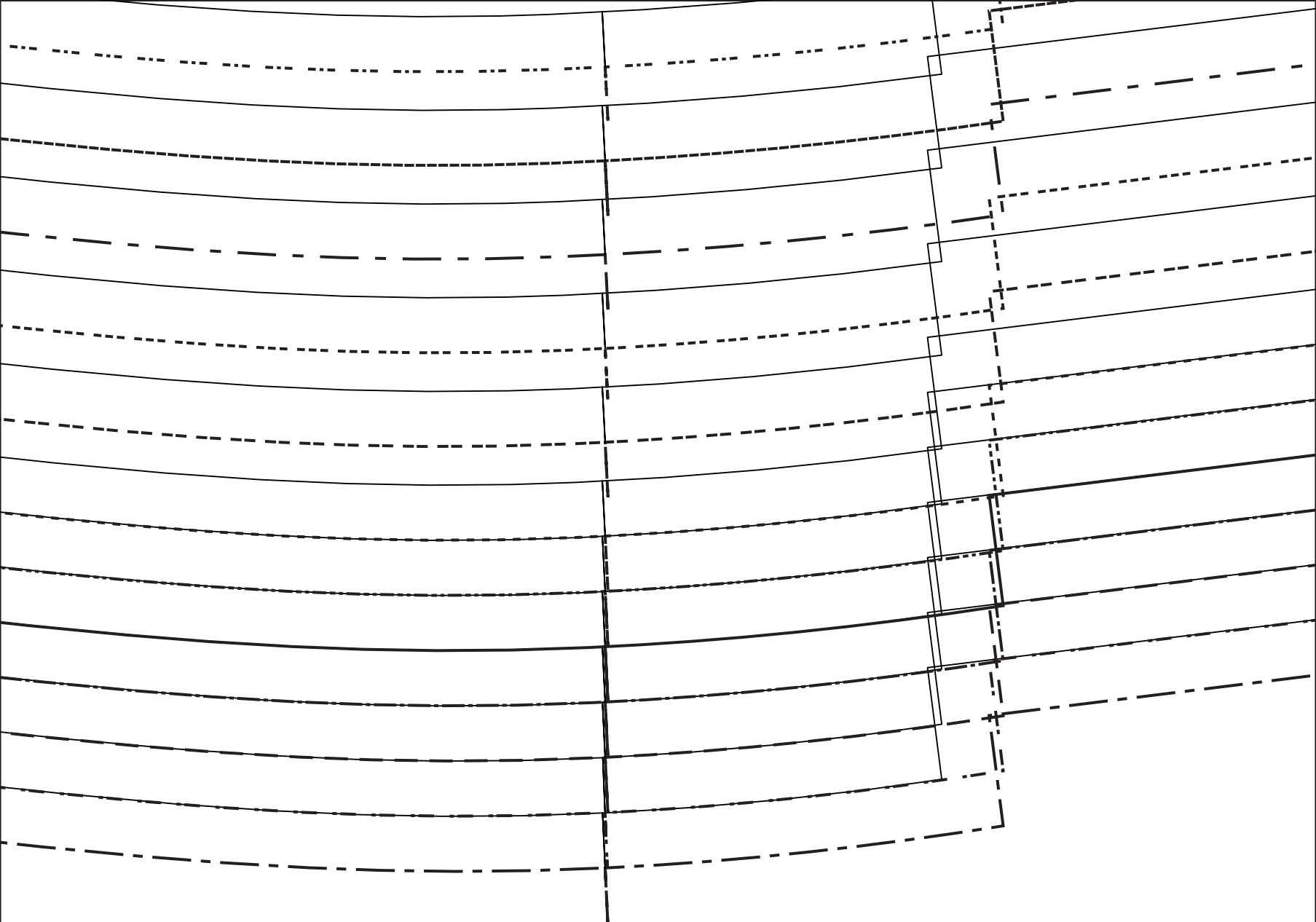

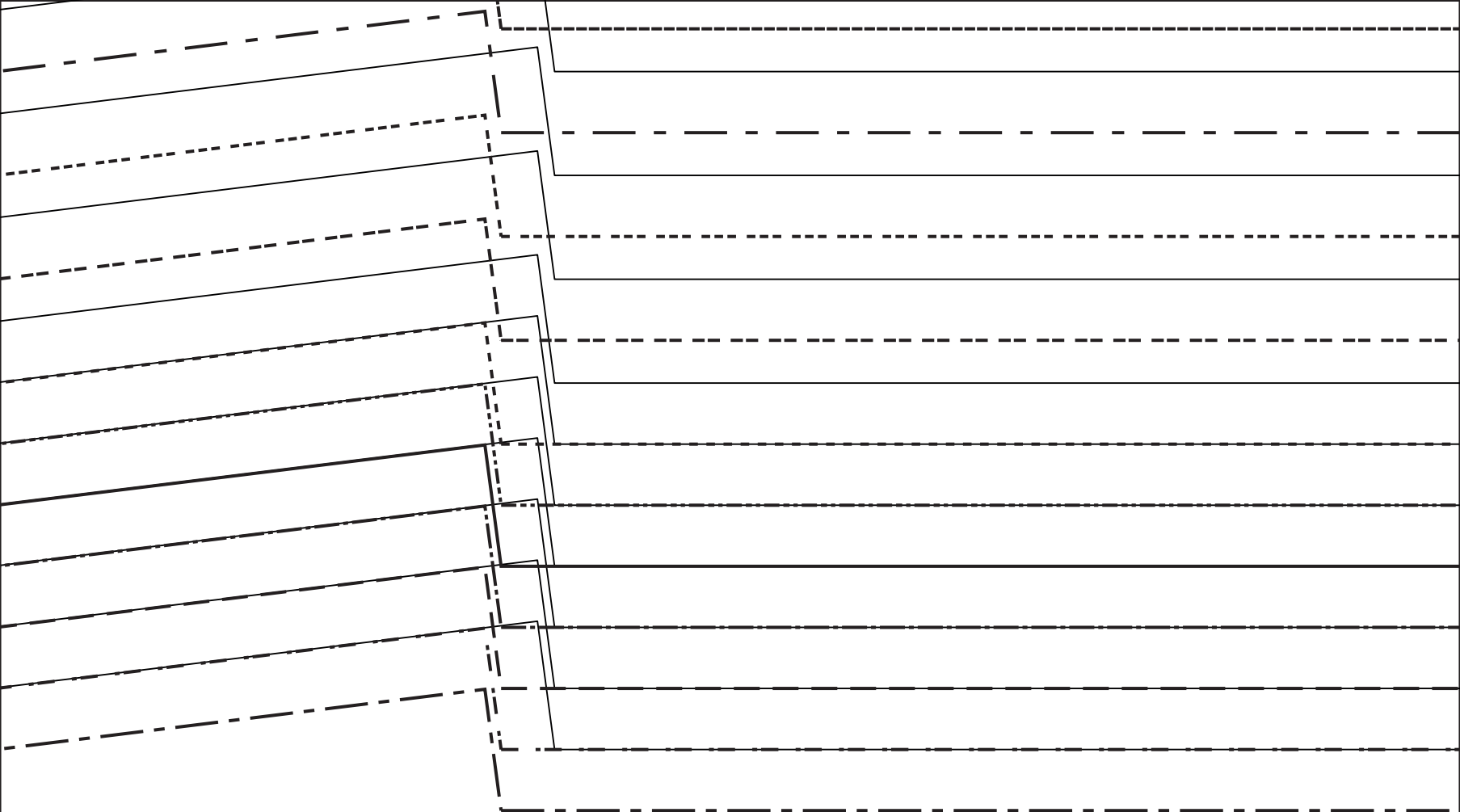

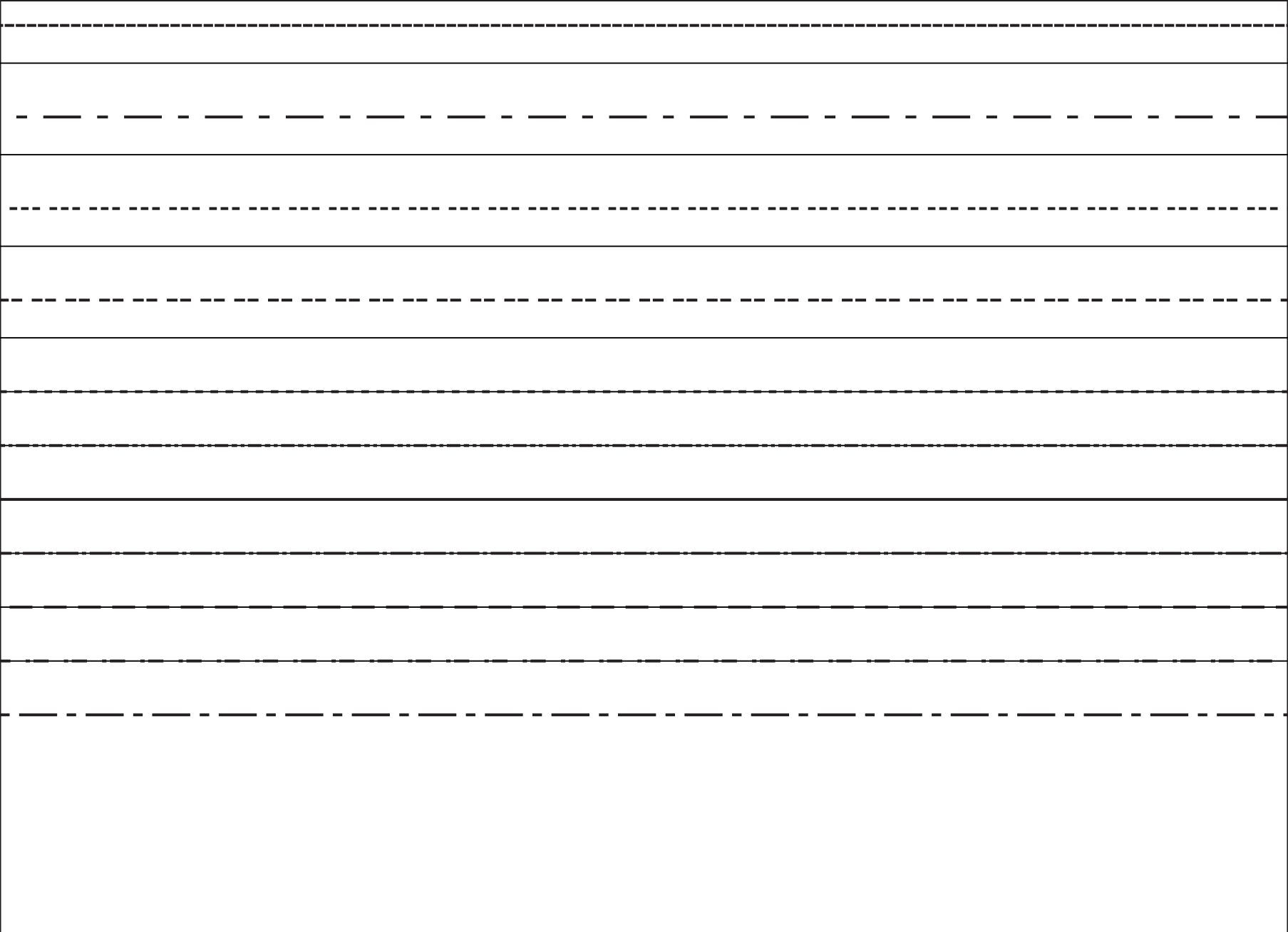

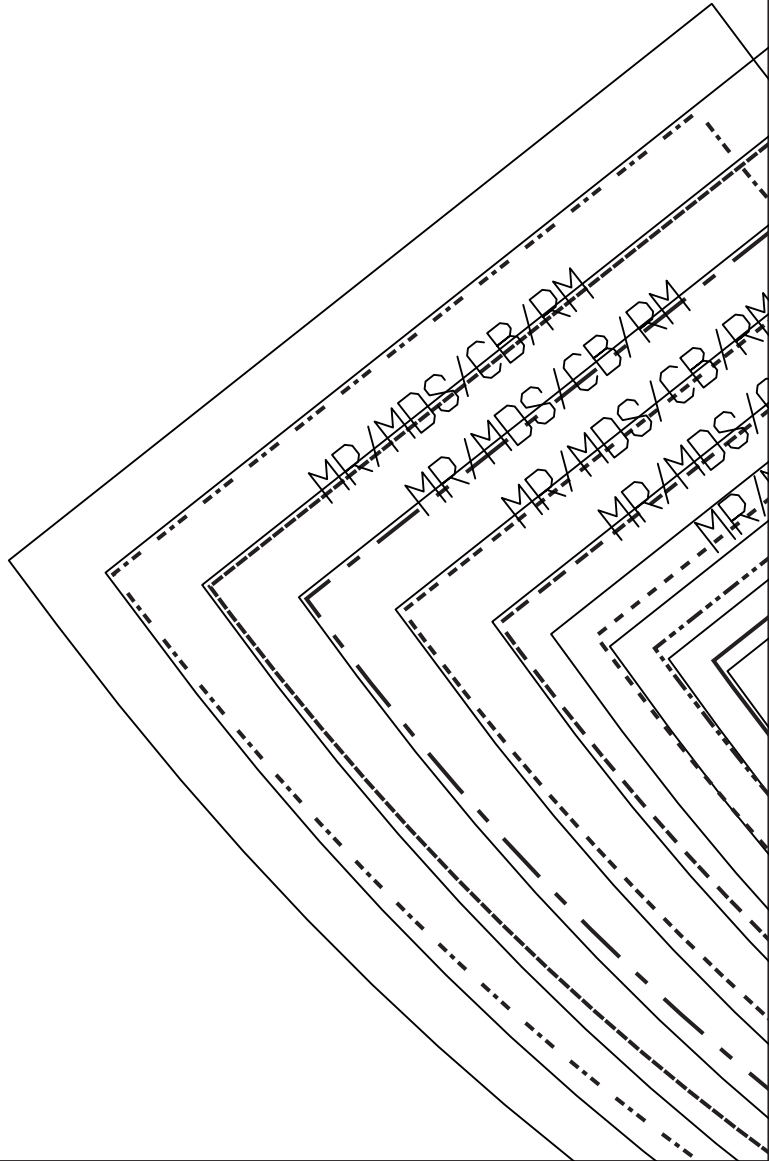
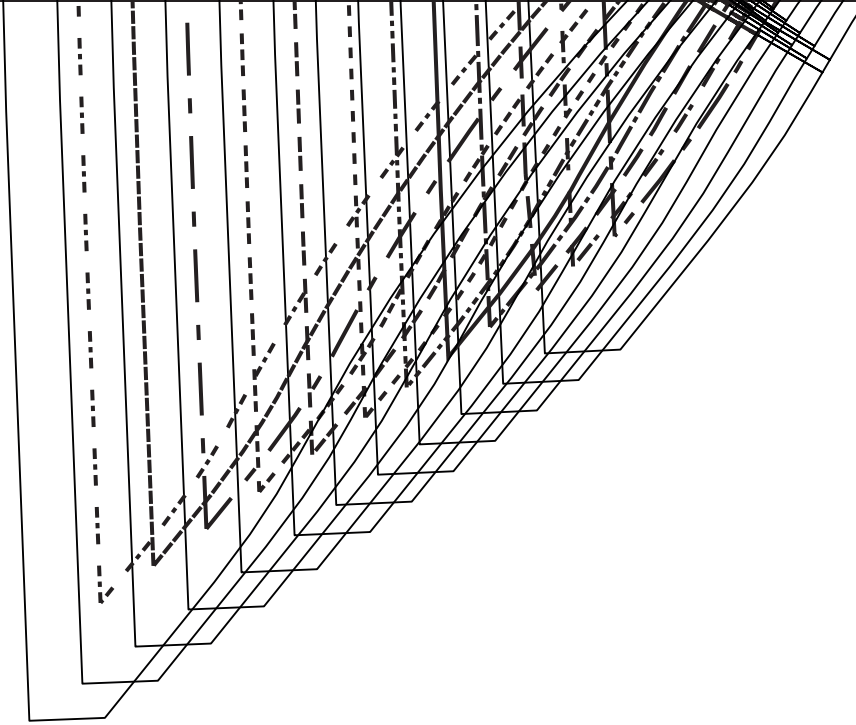

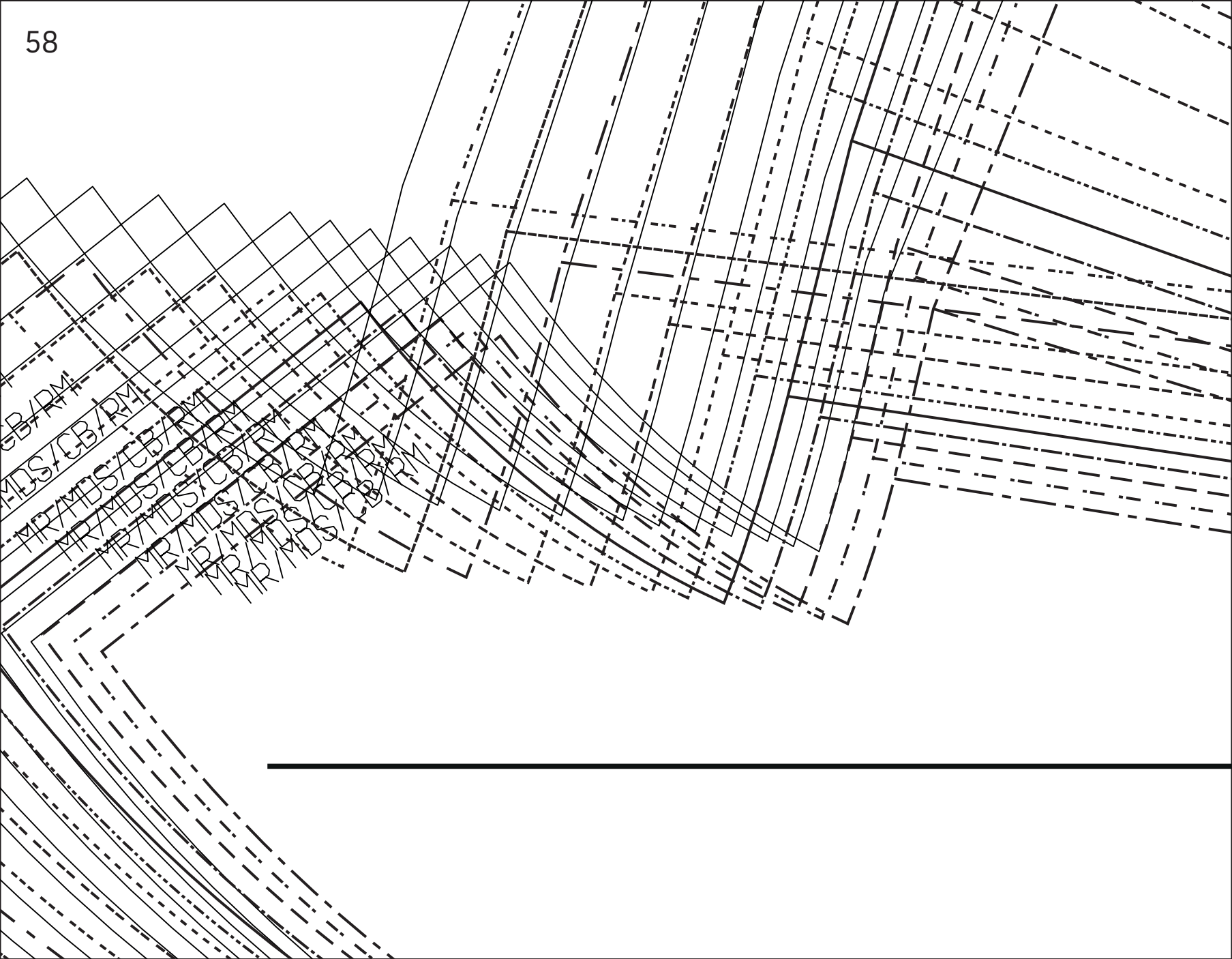

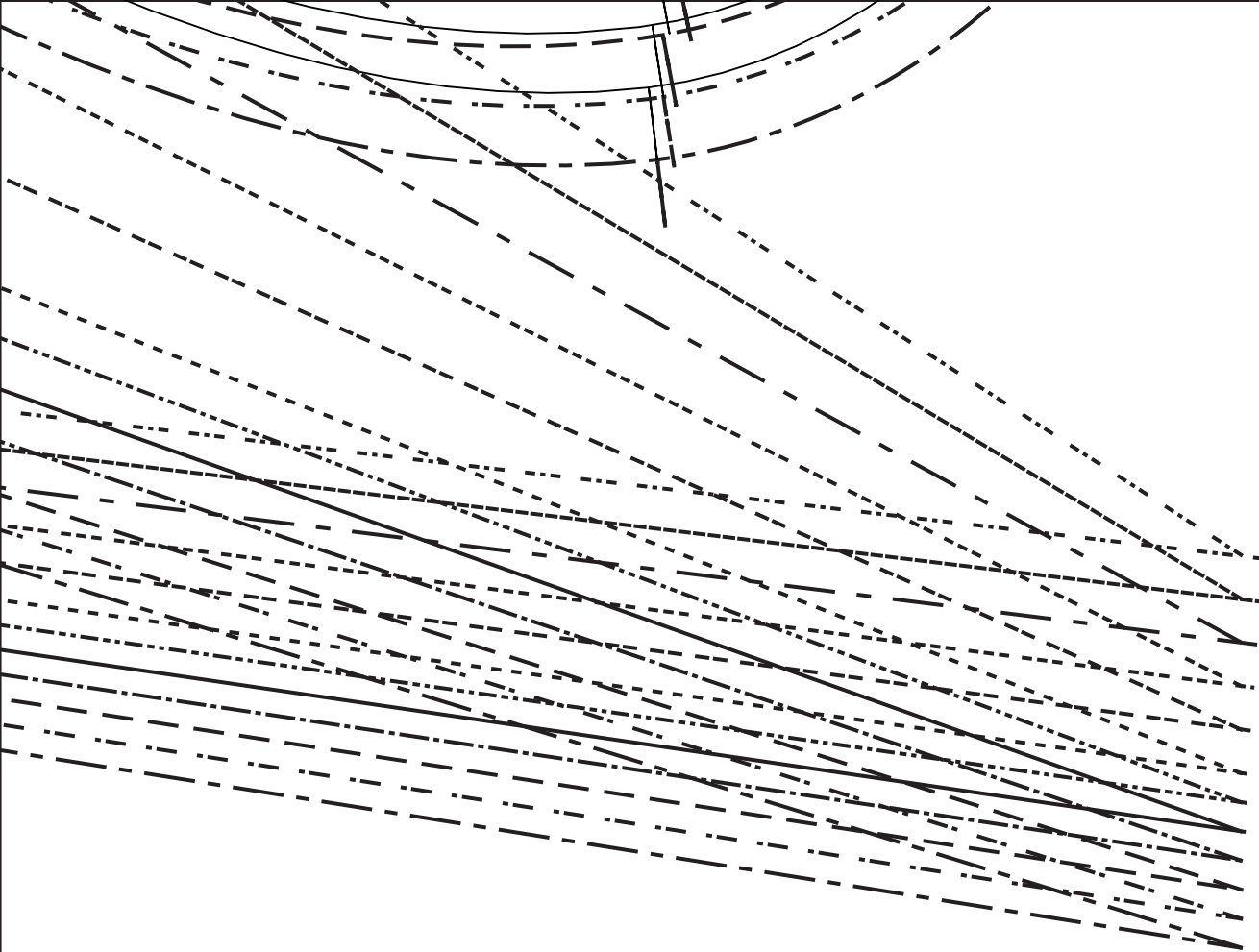

A



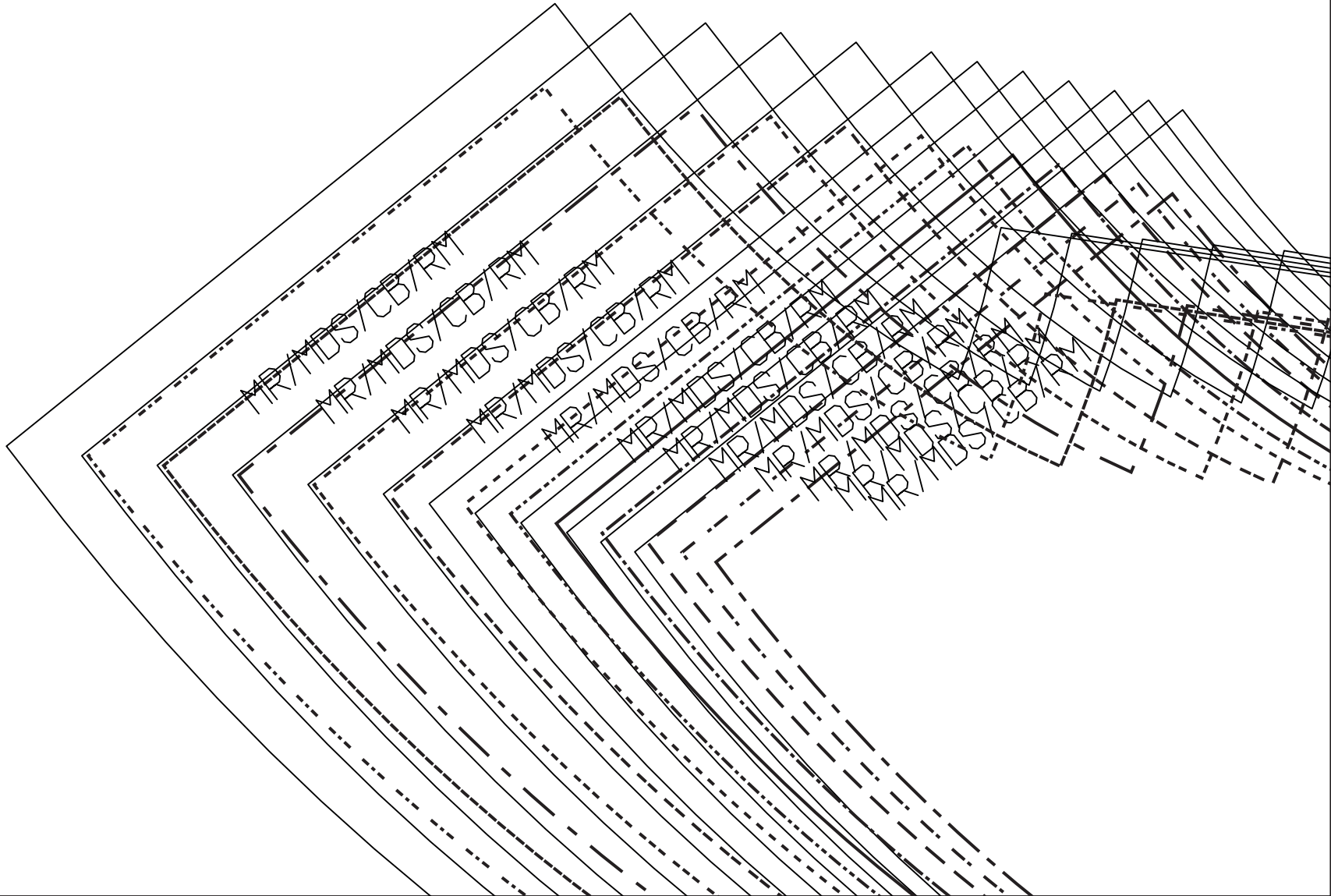

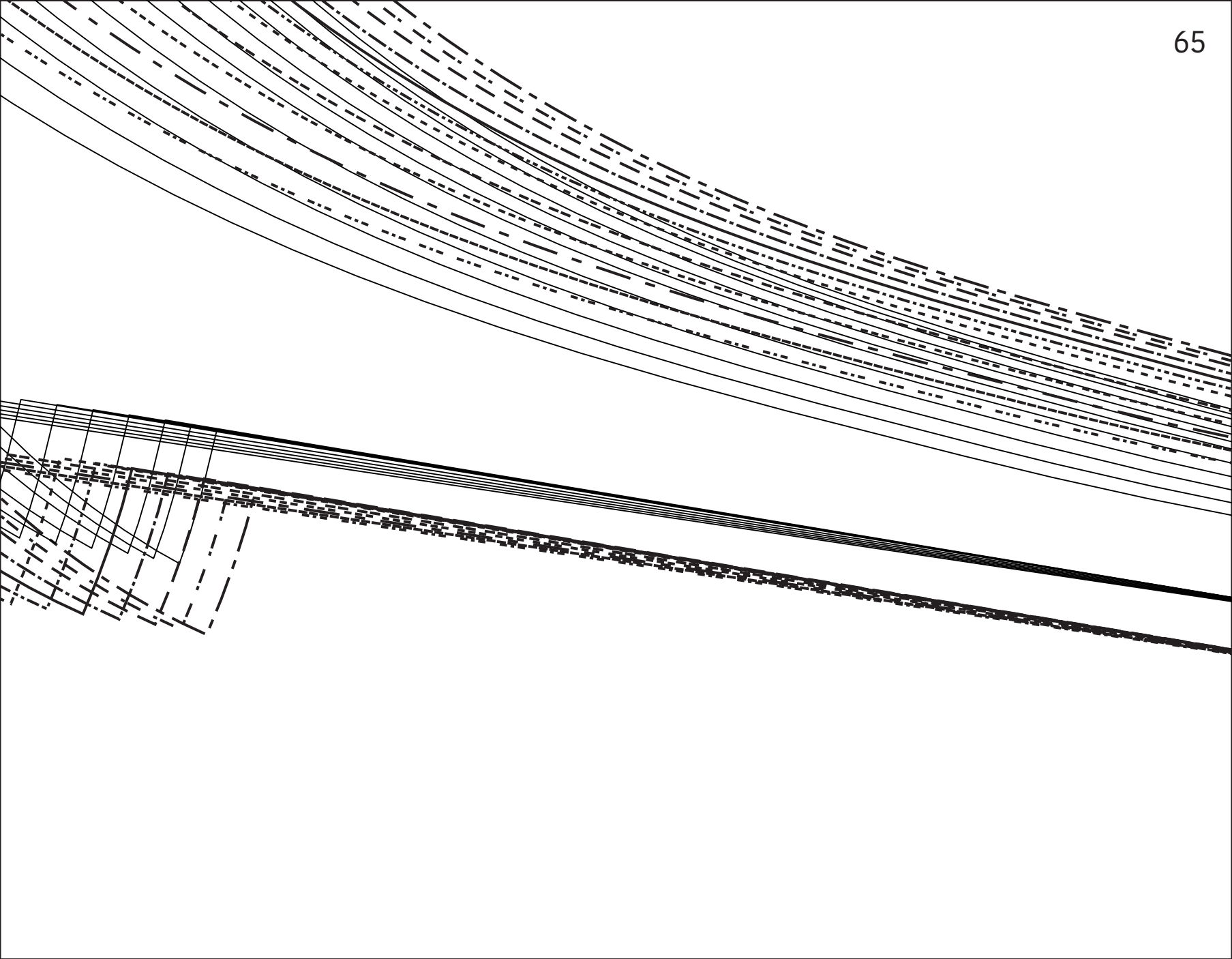

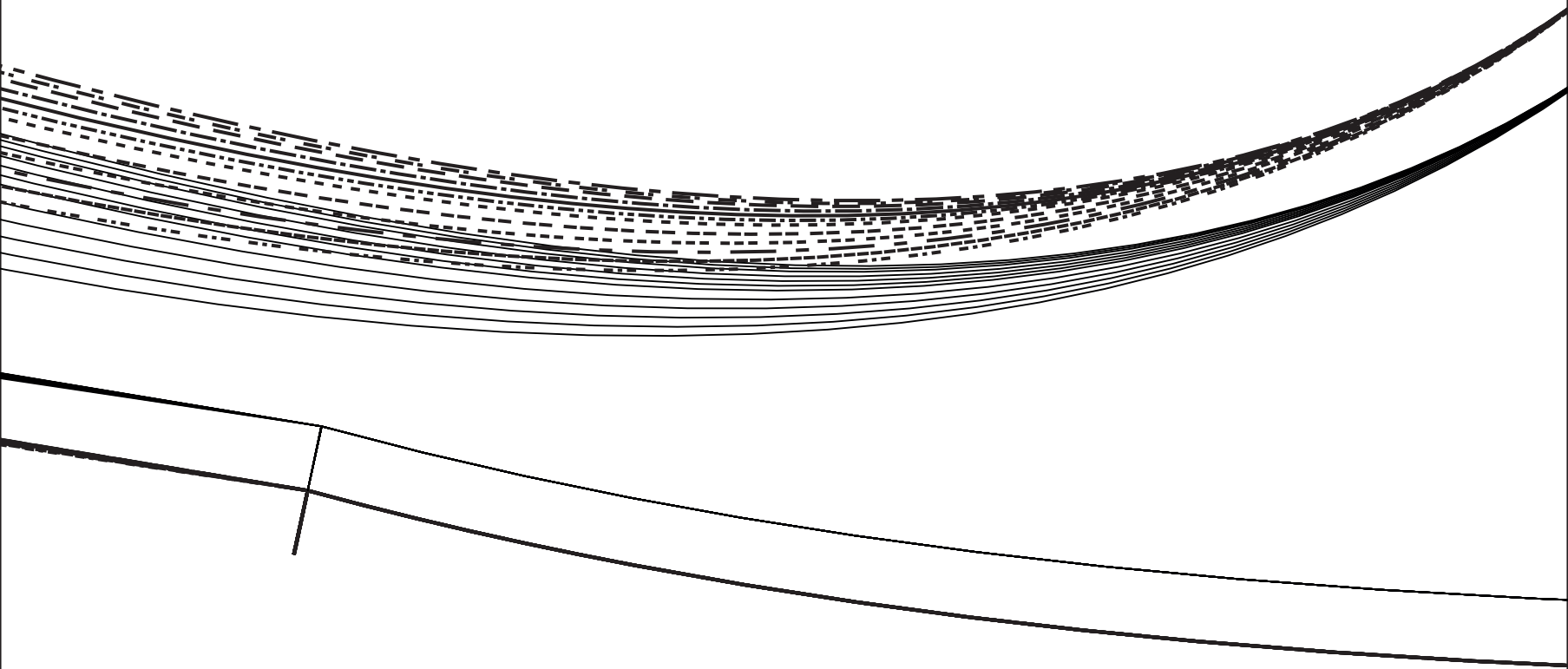

67

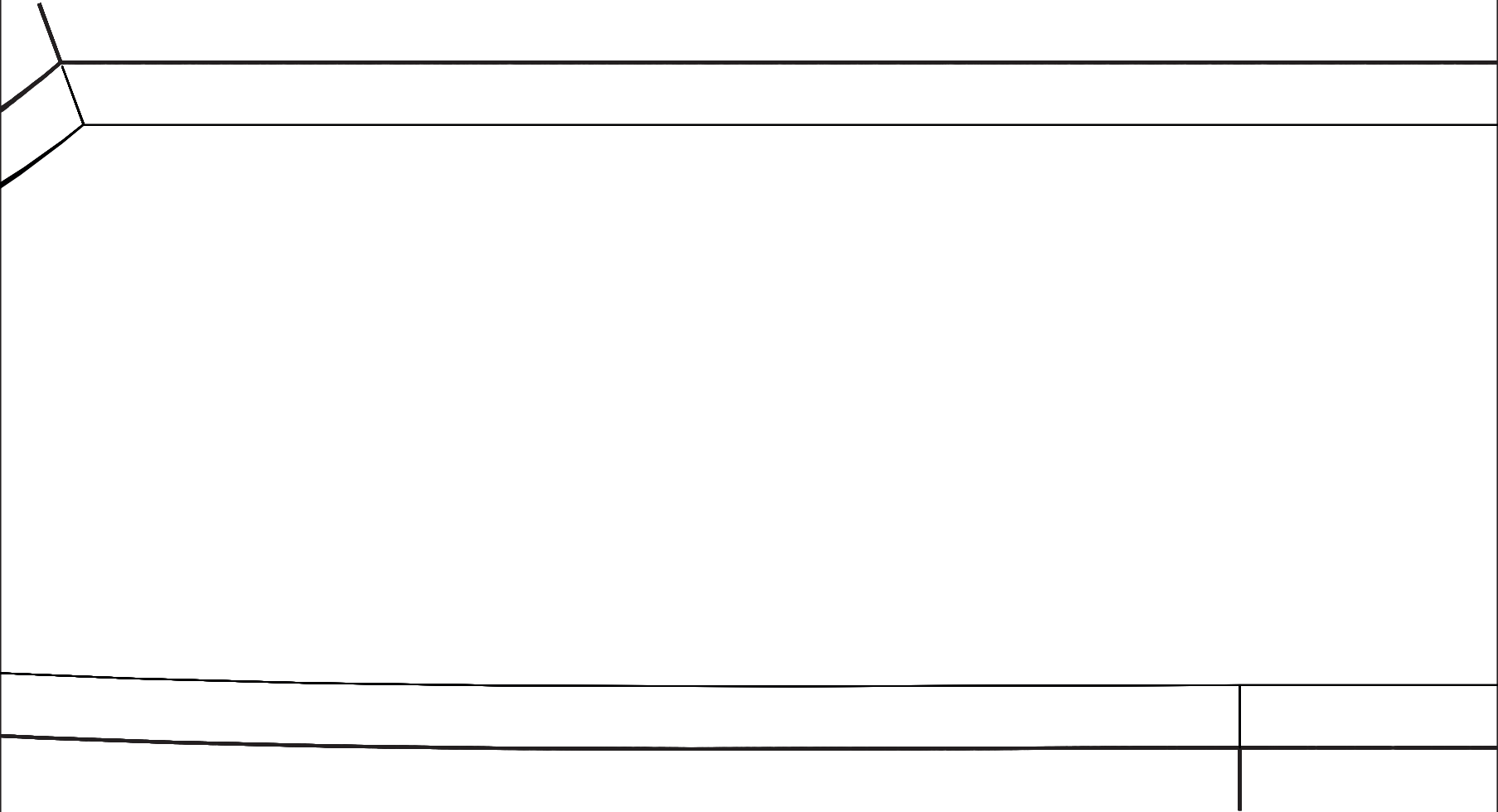

70

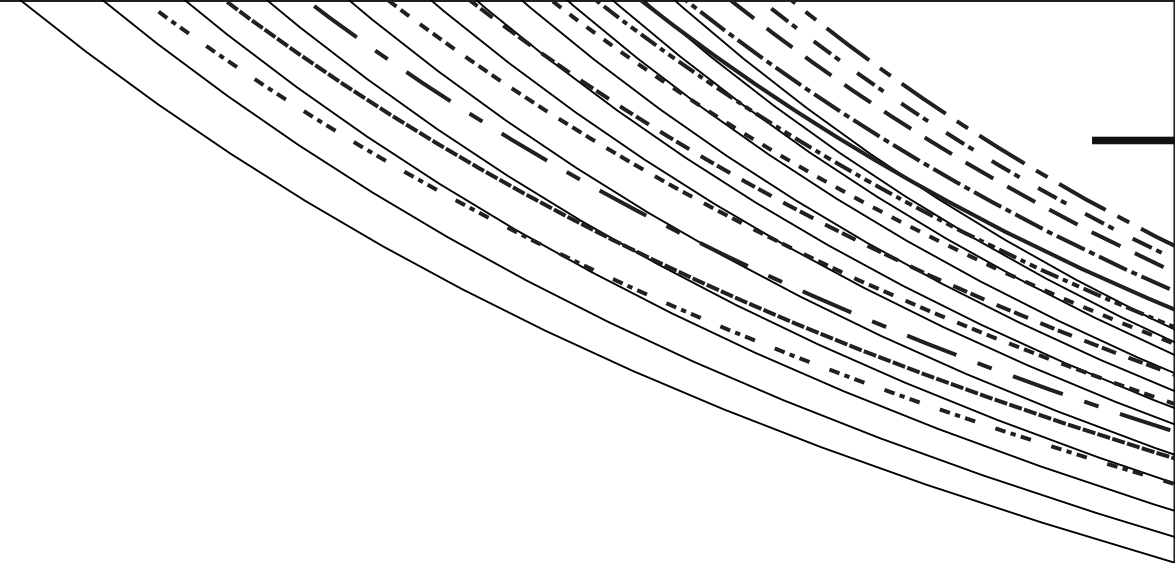

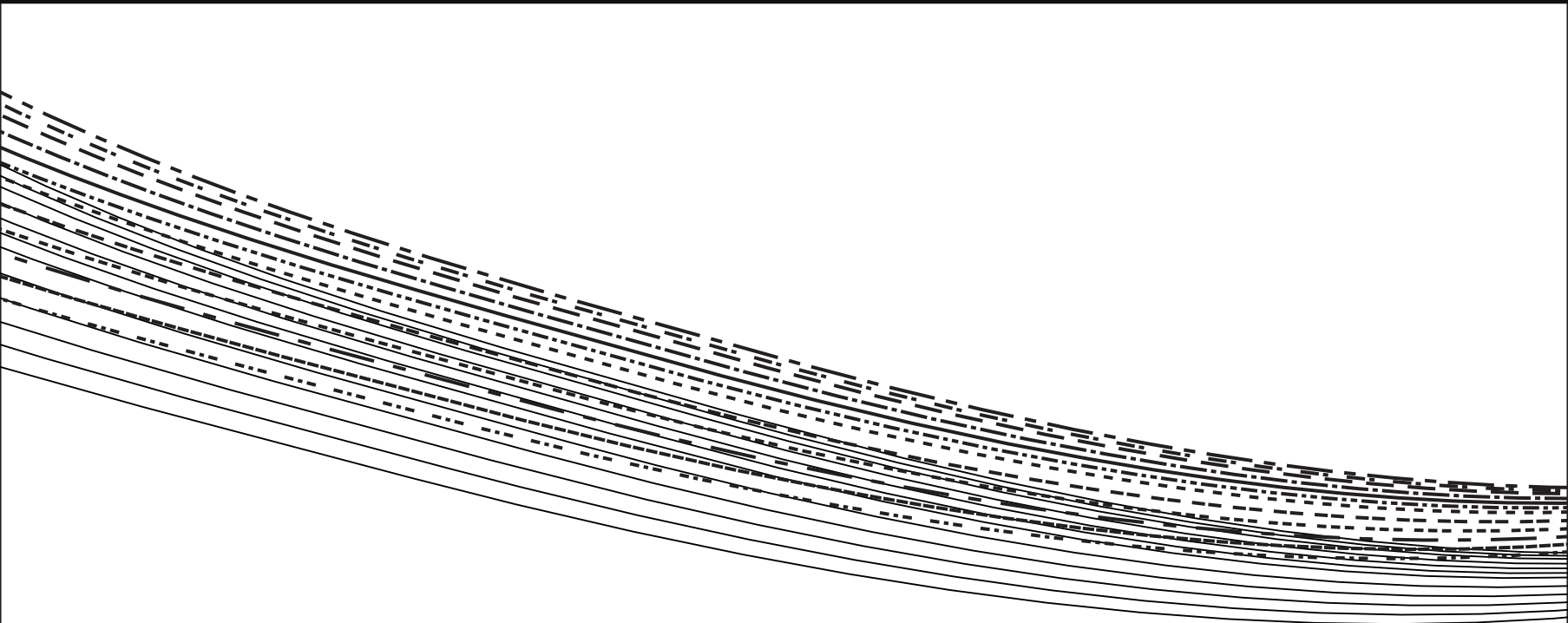

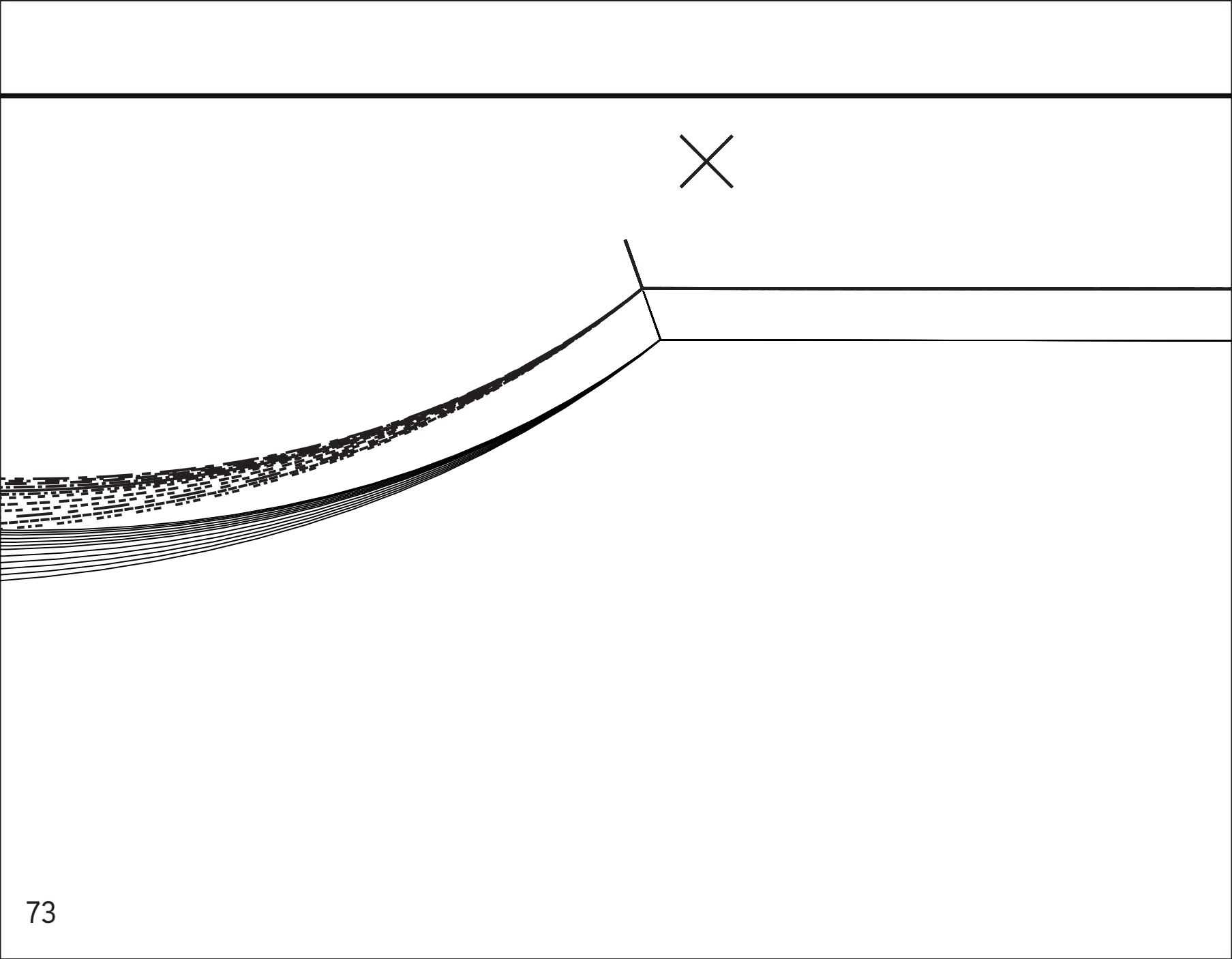

C

